

NASSAU COUNTY PIGGYBACK AGREEMENT

THIS NASSAU COUNTY PIGGYBACK AGREEMENT (hereinafter “Agreement”) is by and between the **NASSAU COUNTY BOARD OF COUNTY COMMISSIONERS**, a political subdivision of the State of Florida, hereinafter called “County” and **KENWORTH OF JACKSONVILLE, INC.**, hereinafter called “Vendor”.

WHEREAS, the County requires the following goods and services: 2025 Kenworth T880 Day Cab Roll-Off Truck; and

WHEREAS, the Vendor has previously entered into a Contract with Florida Sheriff’s Association (hereinafter “Lead Contracting Agency”), pursuant to a formal competitive procurement process under the FSA Cooperative Purchasing Program for the same goods and services (hereinafter “Original Contract”), a copy of which is attached hereto and incorporated herein as “Exhibit A”; and

WHEREAS, Section 1-141(d)(3) of the Nassau County Code of Ordinances, Purchasing Policy, allows for piggybacking for the same goods and services; and

WHEREAS, the County desires to access the Original Contract with the Vendor for the acquisition of said goods and services in accordance with the terms of the “Exhibit A”.

NOW, THEREFORE, in consideration of the mutual covenants and agreements herein contained, the parties hereto agree as follows:

SECTION 1. Recitals.

1.1 The above recitals are true and correct and are incorporated herein, in their entirety, by this reference.

SECTION 2. Exhibits.

2.1 The Exhibits listed below are the exhibits incorporated into and made part of this Agreement:

- Exhibit A** ORIGINAL CONTRACT WITH LEAD CONTRACTING AGENCY – FSA COOPERATIVE PURCHASING PROGRAM, FSA23-VEH21.0: HEAVY TRUCKS & BUSES
- Exhibit B** VENDOR’S QUOTE/PROPOSAL
- Exhibit C** INSURANCE DOCUMENTS

SECTION 3. Prices, Parties and Additional Terms and Conditions.

3.1 The Vendor shall be compensated in an amount not to exceed Two Hundred Seventy Thousand, Eight Hundred Ninety Five Dollars and 50/100 (\$270,895.50) in accordance with Vendor's Quote/Proposal attached hereto and incorporated herein as Exhibit "B." The Vendor's Quote/Proposal shall reflect the pricing under the same terms and conditions as contained in Exhibit "A" or lower if needed but, cannot exceed the pricing listed in Exhibit "A".

3.2 All references to the Lead Contracting Agency in Exhibit "A" shall for the purpose of this Agreement be replaced with the words of "Nassau County" or "County".

3.3 Any additional terms or conditions not set forth in this Agreement or any attachments whether submitted purposely or inadvertently, shall have no force or effect. In the event of any conflict between the terms of this Agreement and the terms of the Original Contract or any attachments, the terms of this Agreement shall prevail.

SECTION 4. Term of Agreement.

4.1 Notwithstanding any other provision of the Original Contract to the contrary, the term of this Agreement shall begin upon the date fully executed and end one year from date of execution.

SECTION 5. Termination for Default.

5.1 If the Vendor fails to perform any of its obligations under this Agreement, and if such default remains uncured for a period of more than fifteen (15) days after notice thereof was given in writing by the County to the Vendor, then the County may, without prejudice to any right or remedy the County may have, terminate this Agreement.

5.2 Upon termination of this Agreement, the Vendor shall immediately (1) stop work on the date specified; (2) terminate and settle all orders and subcontracts relating to the performance of the terminated work; (3) transfer all work in process, completed work, and other materials related to the terminated work to the County; and (4) render to the County all property belonging to the County, including but not limited to, equipment, books, and records.

SECTION 6. Termination for Convenience.

6.1 The County reserves the right to terminate this Agreement in whole or part by giving the Vendor written notice at least thirty (30) days prior to the effective date of the termination. Upon receipt of written notice of termination from the County, the Vendor shall only provide those services and/or materials specifically approved or directed by the County. All other rights

and duties of the parties under the Agreement shall continue during such notice period, and the County shall continue to be responsible to the Vendor for the payment of any obligations to the extent such responsibility has not been excused by breach or default of the Vendor. The Vendor shall promptly contact the County to make arrangements to render to the County all property belonging to the County, including but not limited to, equipment, books, and records.

SECTION 7. Public Records.

7.1 The County is a public agency subject to Chapter 119, Florida Statutes. **IF THE VENDOR HAS QUESTIONS REGARDING THE APPLICATION OF CHAPTER 119, FLORIDA STATUTES, TO THE VENDOR’S DUTY TO PROVIDE PUBLIC RECORDS RELATING TO THIS AGREEMENT, CONTACT THE CUSTODIAN OF PUBLIC RECORDS AT (904) 530-6090, RECORDS@NASSAUCOUNTYFL.COM, 96135 NASSAU PLACE, SUITE 6, YULEE, FLORIDA 32097.** Under this Agreement, to the extent that the Vendor is providing services to the County, and pursuant to Section 119.0701, Florida Statutes, the Vendor shall:

- a. Keep and maintain public records required by the public agency to perform the service.
- b. Upon request from the public agency’s custodian of public records, provide the public agency with a copy of the requested records or allow the records to be inspected or copied within a reasonable time at a cost that does not exceed the cost provided in this chapter or as otherwise provided by law.
- c. Ensure that public records that are exempt or confidential and exempt from public records disclosure requirements are not disclosed except as authorized by law for the duration of the agreement term and following completion of the Agreement if the Vendor does not transfer the records to the public agency.
- d. Upon completion of the Agreement, transfer, at no cost, to the public agency all public records in possession of the Vendor or keep and maintain public records required by the public agency to perform the service. If the Vendor transfers all public records to the public agency upon completion of the Agreement, the Vendor shall destroy any duplicate public records that are exempt or confidential

and exempt from public records disclosure requirements. If the Vendor keeps and maintains public records upon completion of the Agreement, the Vendor shall meet all applicable requirements for retaining public records. All records stored electronically must be provided to the public agency, upon request from the public agency's custodian of public records, in a format that is compatible with the information technology systems of the County.

- e. A request to inspect or copy public records relating to a Nassau County Agreement must be made directly to the Nassau County Custodian of Public Records. If Nassau County does not possess the requested records due to the Vendor maintaining the public records, then Nassau County shall immediately notify the Vendor of the request for records. The Vendor must provide the records to Nassau County or allow the records to be inspected or copied within a reasonable time. If the Vendor does not comply with Nassau County's request for records, Nassau County shall be entitled to enforce the Agreement provisions herein for failure to comply with the terms of the Agreement. Any Vendor which fails to provide public records to Nassau County within a reasonable time may also be subject to penalties as provided under Section 119.10, Florida Statutes, including punishment by fine or may be guilty of committing a misdemeanor of the first degree for any willful and knowing violation.
- f. If a civil action is filed against the Vendor to compel production of public records relating to the Agreement, the Court shall assess and award against the Vendor the reasonable costs of enforcement, including reasonable attorney fees if:
 - (a) The Court determines that the Vendor unlawfully refused to comply with the public records request within a reasonable time; and
 - (b) At least eight (8) business days before filing the action, the plaintiff provided written notice of the public records request, including a statement that the Vendor has not complied with the request, to the County and to the Vendor.
- g. A notice complies with this Section, if it is sent to the County's custodian of public records and to the Vendor at the Vendor's address listed on its Agreement with the County or to the Vendor's registered agent. Such notices shall be sent pursuant to Section 11.1 hereinbelow.

- h. If the Vendor complies with a public records request within eight (8) business days after the notice is sent, the Vendor is not liable for the reasonable costs of enforcement.
- i. In reference to any public records requested under this Agreement, the Vendor shall identify and mark specifically any information which the Vendor considers confidential and/or proprietary, inclusive of trade secrets as defined in Section 812.081, Florida Statutes, and which the Vendor believes to be exempt from disclosure, citing specifically the applicable exempting law and including a brief written explanation as to why the cited Statute is applicable to the information claimed as confidential and/or proprietary information. All materials shall be segregated and clearly identified as "EXEMPT FROM PUBLIC DISCLOSURE."
- j. In conjunction with the confidential and/or proprietary information designation, the Vendor acknowledges and agrees that after notice from County, the Vendor shall respond to a notice from the County immediately, but no later than 10 calendar days from the date of notification or the Vendor shall be deemed to have waived and consented to the release of the confidential and/or proprietary designated materials.
- k. The Vendor further agrees that by designation of the confidential/proprietary material, the Vendor shall defend the County (and its employees, agents and elected and appointed officials) against all claims and actions (whether or not a lawsuit is commenced) related to the Vendor's designation of the material as exempt from public disclosure and to hold harmless the County (and its employees, agents and elected and appointed officials) from any award to a plaintiff for damages, costs and attorneys' fees, incurred by the County by reason of any claim or action related to the Vendor's designation of material as exempt from public disclosure.

SECTION 8. E-Verify.

8.1 The Vendor shall comply with Section 448.095, Florida Statutes, and use the United States Department of Homeland Security's E-Verify system ("E-Verify") to verify the employment eligibility of all persons hired by the Vendor during the term of this Agreement to work in Florida. Additionally, if the Vendor uses subcontractors to perform any portion of the

work (under this Agreement), the Vendor shall include a requirement in the subcontractor's contract that the subcontractor use E-Verify to verify the employment eligibility of all persons hired by subcontractor to perform any such portion of the work. Answers to questions regarding E-Verify as well as instructions on enrollment may be found at the E-Verify website: www.uscis.gov/e-verify.

8.2 The Vendor shall maintain records of its participation and compliance with the provisions of the E-Verify program, including participation by its subcontractors as provided above, and to make such records available to the County or other authorized entity consistent with the terms of the Vendor's enrollment in the program. This includes maintaining a copy of proof of the Vendor's and subcontractors' enrollment in the E-Verify program. If the Vendor enters into a contract with a subcontractor, the subcontractor shall provide the Vendor with an affidavit stating that the subcontractor does not employ, contract with, or subcontract with an unauthorized alien. The Vendor shall maintain a copy of such affidavit for the duration of the Agreement.

8.3 Compliance with the terms of the E-Verify program provision is made an express condition of this Agreement and the County may treat a failure to comply as a material breach of the Agreement. If the County terminates the Agreement pursuant to Section 448.095(2)(c), Florida Statutes, the Vendor may not be awarded a public contract for at least one (1) year after the date on which the Agreement was terminated and the Vendor is liable for any additional costs incurred by the County as a result of the termination of this Agreement.

SECTION 9. Prompt Payment Act.

9.1 All payments shall be made in accordance with the Local Government Prompt Payment Act, Chapter 218, Florida Statutes.

SECTION 10. Indemnity.

10.1 The Vendor shall indemnify and hold harmless the County and its agents and employees from all claims, liabilities, damages, losses, expenses and costs, including attorney's fees, arising out of or associated with or caused by the negligence, recklessness, or intentionally wrongful conduct of the Vendor or any persons employed or utilized by the Vendor, in the performance of this Contract. The Vendor shall, at its own expense, defend any and all such actions, suits, or proceedings which may be brought against the County in connection with the Vendor's performance under this Contract.

SECTION 11. Notices.

11.1 All notices to the County under this Agreement shall be deemed served if sent in a manner requiring signed receipt of delivery, such as Federal Express, or if mailed, Registered or Certified Mail, return receipt requested as follows:

Nassau County
Director of Public Works Director
45195 Musselwhite Road
Callahan, Florida 32011
904-530-6100
dpodiak@nassaucountyfl.com

SECTION 12. Fiscal Funding.

12.1 This Agreement is subject to the availability of the County funding for each item and obligation and may be terminated without liability, penalty or further obligation other than payment of fees then due and owing.

SECTION 13. Indemnification.

13.1 The Vendor shall indemnify and hold harmless the County and its agents and employees from all claims, liabilities, damages, losses, expenses and costs, including attorney's fees, arising out of or associated with or caused by the negligence, recklessness, or intentionally wrongful conduct of the Vendor or any persons employed or utilized by the Vendor, in the performance of this Agreement. The Vendor shall, at its own expense, defend any and all such actions, suits, or proceedings which may be brought against the County in connection with the Vendor's performance under this Agreement.

SECTION 14. Insurance.

14.1 The Vendor shall provide and maintain at all times during the term of this Agreement, without cost or expense to the County, such commercial (occurrence form) or comprehensive general liability, workers compensation, professional liability, and other insurance policies as detailed in Exhibit "B". The policy limits required are to be considered minimum amounts.

14.2 The Vendor shall provide to the County a Certificate of Insurance for all policies of insurance and renewals thereof in a form acceptable to the County. Said certificates shall provide that the Nassau County Board of County Commissioners is an additional insured, and

that the County shall be notified in writing of any reduction, cancellation or substantial change of policy or policies at least thirty (30) days prior to the effective date of said action with the exception of ten (10) days for non-payment. All insurance policies shall be issued by responsible companies who are acceptable to the County and licensed and authorized under the laws of the State of Florida.

SECTION 15. Independent Vendor Status.

15.1 The Vendor shall perform the services under this Agreement as an independent contractor and nothing contained herein shall be construed to be inconsistent with this relationship or status. Nothing in this Agreement shall be interpreted or construed to constitute the Vendor or any of its agents or employees to be an agent, employee or representative of the County.

15.2 The Vendor and the County agree that during the term of this Agreement: (a) the Vendor has the right to perform services for others; (b) the Vendor has the right to perform the services required by this Agreement; and (c) the Vendor has the right to hire assistants as subcontractors, or to use employees to provide the services required by this Agreement.

SECTION 16. Taxes, Liens, Licenses and Permits.

16.1 The Vendor recognizes that the County, by virtue of its sovereignty, is not required to pay any taxes on the services or goods purchased under the terms of this Agreement. As such, the Vendor shall refrain from including taxes in any billing. The Vendor is placed on notice that this exemption generally does not apply to nongovernmental entities, contractors, or subcontractors. Any questions regarding this tax exemption shall be addressed to the County Manager.

16.2 The Vendor shall secure and maintain all licenses and permits required to perform the services under this Agreement and to pay any and all applicable sales or use tax, or any other tax or assessment which shall be imposed or assessed by any and all governmental authorities, required under this Agreement, and to meet all federal, state, county and municipal laws, ordinances, policies and rules.

16.3 The Vendor acknowledges that property being improved that is titled to the County, shall not be subject to a lien of any kind for any reason. The Vendor shall include notice of such exemptions in any subcontracts and purchase orders issued under this Agreement.

SECTION 17. Assignment.

17.1 The Vendor shall not assign, sublet, convey or transfer its interest in this Agreement without the prior written consent of the County.

SECTION 18. Compliance with Laws.

18.1 The Vendor agrees to comply with all applicable federal, state and local laws, rules and regulations during the term of this Agreement.

SECTION 19. Governing Law and Venue.

19.1 This Agreement shall be interpreted and construed in accordance with the laws of the State of Florida with Venue for any action brought in Nassau County, Florida.

SECTION 20. Severability.

20.1 If any section, subsection, sentence, clause, phrase, or portion of this Agreement is, for any reason, held invalid, unconstitutional, or unenforceable by any Court of Competent Jurisdiction, such portion shall be deemed as a separate, distinct, and independent provision, and such holding shall not affect the validity of the remaining portions thereof.

(Remainder of page intentionally blank.)

IN WITNESS WHEREOF, the parties have executed this Agreement which shall be deemed an original on the day and year last written below.

**BOARD OF COUNTY COMMISSIONERS OF
NASSAU COUNTY, FLORIDA**

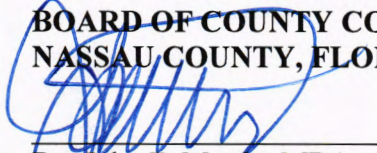

By: John F. Martin, MBA
Its: Chairman

Date: September 9, 2024

Attest as to authenticity of the
Chair's signature:

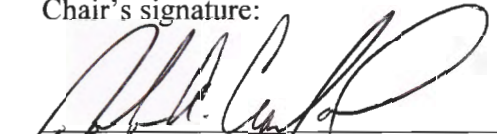

JOHN A. CRAWFORD
Its: Ex-Officio Clerk

Approved as to form and legality by the
Nassau County Attorney

Denise C. May

DENISE C. MAY

KENWORTH OF JACKSONVILLE, INC.

David Butler

By: David M. Butler

Its: CFO

Date: 8/7/2024

EXHIBIT A

Original Contract With Lead Agency

FSA Cooperative Purchasing Program



FSA23-VEH21.0: Heavy Trucks & Buses Final Award Contract Packet



Protecting, Leading & Uniting...since 1893

FLORIDA SHERIFFS ASSOCIATION

2617 Mahan Drive, Tallahassee, Florida 32308
P.O. Box 12519 • Tallahassee, Florida 32317-2519

p: (850) 877-2165
f: (850) 878-8665
www.flsheriffs.org  

Notice of Final Award FSA23-VEH21.0: Heavy Trucks & Buses

Date: October 1, 2023

To: Bidders and Purchasers

From: Hugh Oliver, Cooperative Purchasing Program Manger

Re: Notice of Final Award for FSA23-VEH21.0: Heavy Trucks & Buses

Florida Sheriffs Association (FSA) has completed its 21st year of the cooperative purchasing heavy trucks and buses contract. FSA is issuing the Notice of Final Award for contract FSA23-VEH21.0: Heavy Trucks & Buses that will be effective from October 1, 2023, through September 30, 2024. This year's bid included 80 items. The contract will offer class 3-5 cab & chassis trucks and buses.

The competitive process for this award began in May 2023, when stakeholders were surveyed regarding procurement needs. Items were added based on survey results and the Fleet Advisory Committee's review of products.

An advertisement for the Invitation to Bid was published in the Florida Administrative Weekly, as well as the State of Florida's Office of Supplier Diversity and the FSA websites. On May 5, 2023, a direct notification was sent to 716 prospective bidders to participate in a voluntary bidder workshop. The ITB advertisement resulted in 81 pre-bid attendees or waivers. Of these respondents, 30 submitted bids and 29 qualified. FSA has identified intended awardees in the attached Final Award Report. The Final Award Report shows up to three lowest bidders per item, per zone.

The Florida Sheriffs Association Cooperative Purchasing Program has followed the Contract Terms and Conditions for this procurement. Bidders that become awarded vendors are governed by their manufacturer agreements and the Contract Terms and Conditions.

Contract pricing will be extended and guaranteed to the Florida Sheriffs Association, any unit of local government, political subdivision or agency of the State of Florida, or to other entities approved by manufacturers to buy from this contract, which can include out-of-state sales. Vendors that wish to extend contract pricing to entities other than those defined here are governed by their manufacturer's agreement. All purchasers are bound by state law, local ordinances, rules, and regulations for purchases made under this contract.

FSA Cooperative Purchasing Program



FSA23-VEH21.0: Heavy Trucks & Buses Current Contract Prices

Item #	Item Group	Item	Model #	Link
1	Buses Electric: 19 to 20 Passenger Capacity Range, Van-Type Cutaway Chassis	Endera B-Series	B-Series	https://www.myvendorlink.com/external/award?s=152477&i=1
2	Buses Electric: 20 to 52 Passenger Capacity Range, Conventional-Type Chassis	Bluebird Vision Electric	Vision Electric	https://www.myvendorlink.com/external/award?s=152477&i=2
3	Buses Electric: 20 to 52 Passenger Capacity Range, Conventional-Type Chassis	Bluebird All-American Electric	T3RE	https://www.myvendorlink.com/external/award?s=152477&i=3
5	Buses Electric: 20 to 52 Passenger Capacity Range, Conventional-Type Chassis	Phoenix Motorcars Z600 Type A School Bus	Z600	https://www.myvendorlink.com/external/award?s=152477&i=5
6	Buses Electric: 44 To 80 Passenger Capacity Range, Commercial-Type Chassis	BYD The Dreamer	Type D Electric School Bus	https://www.myvendorlink.com/external/award?s=152477&i=6
7	Buses: 14 to 25 Passenger Capacity Range, Van-Type Cutaway Chassis	Endera B-Series	B-Series	https://www.myvendorlink.com/external/award?s=152477&i=7
8	Buses: 14 to 25 Passenger Capacity Range, Van-Type Cutaway Chassis	Starcraft Allstar	Allstar	https://www.myvendorlink.com/external/award?s=152477&i=8
9	Buses: 20 to 52 Passenger Capacity Range, Conventional Truck-Type Cutaway Chassis	Bluebird Vision	Vision	https://www.myvendorlink.com/external/award?s=152477&i=9
11	Buses: 20 to 52 Passenger Capacity Range, Conventional Truck-Type Cutaway Chassis	Starcraft Allstar	Allstar	https://www.myvendorlink.com/external/award?s=152477&i=11
12	Buses: 33 to 54 Passenger Capacity Range, Commercial-Type, Rear Engine Chassis	Bluebird T3RE	T3RE	https://www.myvendorlink.com/external/award?s=152477&i=12
13	Buses: 36 to 52 Passenger Capacity Range, Commercial-Type, Front Engine Chassis	Bluebird T3FE	T3FE	https://www.myvendorlink.com/external/award?s=152477&i=13
14	Cab and Chassis Trucks Electric: 54,000 lbs. GVWR 4x6 Semi Tractor	Kenworth T680E	T680E	https://www.myvendorlink.com/external/award?s=152477&i=14
15	Cab and Chassis Trucks Electric: 54,000 lbs. GVWR 4x6 Semi Tractor	Peterbilt 579EV	579EV	https://www.myvendorlink.com/external/award?s=152477&i=15
16	Cab and Chassis Trucks Electric: 54,000 lbs. GVWR 4x6 Semi Tractor	Volvo VNR	VNR	https://www.myvendorlink.com/external/award?s=152477&i=16
18	Cab and Chassis Trucks Electric: Conventional Cab 33,000 lbs. GVWR (DRW) 4x2	International EMV	MV60E	https://www.myvendorlink.com/external/award?s=152477&i=18
19	Cab and Chassis Trucks Electric: Conventional Cab 33,000 lbs. GVWR (DRW) 4x2	Mack MD7 Electric	MDE7	https://www.myvendorlink.com/external/award?s=152477&i=19
20	Cab and Chassis Trucks Electric: Tilt Cab 26,000 lbs. GVWR (DRW) 4x2	Battle Motors LNT	LNT	https://www.myvendorlink.com/external/award?s=152477&i=20
21	Cab and Chassis Trucks Electric: Tilt Cab 26,000 lbs. GVWR (DRW) 4x2	Peterbilt 220EV	220	https://www.myvendorlink.com/external/award?s=152477&i=21
23	Cab and Chassis Trucks: 17,500 lbs. GVWR (DRW) 4x2	Ford F-550 Crew Cab	W5G	https://www.myvendorlink.com/external/award?s=152477&i=23
24	Cab and Chassis Trucks: 17,500 lbs. GVWR (DRW) 4x2	Ford F-550 Super Cab	X5G	https://www.myvendorlink.com/external/award?s=152477&i=24
25	Cab and Chassis Trucks: 17,500 lbs. GVWR (DRW) 4x2	Ford F-600 Super Cab	FK6	https://www.myvendorlink.com/external/award?s=152477&i=25
26	Cab and Chassis Trucks: 17,500 lbs. GVWR (DRW) 4x2	Ford F-550 Regular Cab	F5G	https://www.myvendorlink.com/external/award?s=152477&i=26
27	Cab and Chassis Trucks: 17,500 lbs. GVWR (DRW) 4x2	International CV	515	https://www.myvendorlink.com/external/award?s=152477&i=27
28	Cab and Chassis Trucks: 17,500 lbs. GVWR (DRW) 4x2	Kenworth T180	T180	https://www.myvendorlink.com/external/award?s=152477&i=28
29	Cab and Chassis Trucks: 17,500 lbs. GVWR (DRW) 4x2	Peterbilt 535	535	https://www.myvendorlink.com/external/award?s=152477&i=29
31	Cab and Chassis Trucks: 17,500 lbs. GVWR (DRW) 4x4	Ford F-550 Super Cab	X5H	https://www.myvendorlink.com/external/award?s=152477&i=31
32	Cab and Chassis Trucks: 17,500 lbs. GVWR (DRW) 4x4	Ford F-550 Crew Cab	W5H	https://www.myvendorlink.com/external/award?s=152477&i=32
33	Cab and Chassis Trucks: 17,500 lbs. GVWR (DRW) 4x4	Ford F-550 Regular Cab	F5H	https://www.myvendorlink.com/external/award?s=152477&i=33
34	Cab and Chassis Trucks: 17,500 lbs. GVWR (DRW) 4x4	Ford F-600 Regular Cab	F6L	https://www.myvendorlink.com/external/award?s=152477&i=34
35	Cab and Chassis Trucks: 17,500 lbs. GVWR (DRW) 4x4	International CV	515	https://www.myvendorlink.com/external/award?s=152477&i=35
36	Cab and Chassis Trucks: 25,500 lbs. GVWR (DRW) 4x2	Ford F-650 Regular Cab	F6D	https://www.myvendorlink.com/external/award?s=152477&i=36
37	Cab and Chassis Trucks: 25,500 lbs. GVWR (DRW) 4x2	Freightliner M2	106	https://www.myvendorlink.com/external/award?s=152477&i=37
38	Cab and Chassis Trucks: 25,500 lbs. GVWR (DRW) 4x2	Hino L6	L6	https://www.myvendorlink.com/external/award?s=152477&i=38
39	Cab and Chassis Trucks: 25,500 lbs. GVWR (DRW) 4x2	International MV	607	https://www.myvendorlink.com/external/award?s=152477&i=39
40	Cab and Chassis Trucks: 25,500 lbs. GVWR (DRW) 4x2	Kenworth T280	T280	https://www.myvendorlink.com/external/award?s=152477&i=40
41	Cab and Chassis Trucks: 25,500 lbs. GVWR (DRW) 4x2	Mack MD6	MD6	https://www.myvendorlink.com/external/award?s=152477&i=41
42	Cab and Chassis Trucks: 25,500 lbs. GVWR (DRW) 4x2	Peterbilt 536	536	https://www.myvendorlink.com/external/award?s=152477&i=42
43	Cab and Chassis Trucks: 30,000 lbs. GVWR (DRW) 4x2	Ford F-750 Regular Cab	F7D	https://www.myvendorlink.com/external/award?s=152477&i=43
44	Cab and Chassis Trucks: 30,000 lbs. GVWR (DRW) 4x2	Freightliner M2	106	https://www.myvendorlink.com/external/award?s=152477&i=44
45	Cab and Chassis Trucks: 30,000 lbs. GVWR (DRW) 4x2	Hino L7	L7	https://www.myvendorlink.com/external/award?s=152477&i=45
46	Cab and Chassis Trucks: 30,000 lbs. GVWR (DRW) 4x2	International MV	607	https://www.myvendorlink.com/external/award?s=152477&i=46
47	Cab and Chassis Trucks: 30,000 lbs. GVWR (DRW) 4x2	Kenworth T380	T380	https://www.myvendorlink.com/external/award?s=152477&i=47
48	Cab and Chassis Trucks: 30,000 lbs. GVWR (DRW) 4x2	Mack MD7	MD7	https://www.myvendorlink.com/external/award?s=152477&i=48
49	Cab and Chassis Trucks: 30,000 lbs. GVWR (DRW) 4x2	Peterbilt 537	537	https://www.myvendorlink.com/external/award?s=152477&i=49
50	Cab and Chassis Trucks: 30,000 lbs. GVWR (DRW) 4x2	Western Star 47X	47X	https://www.myvendorlink.com/external/award?s=152477&i=50
51	Cab and Chassis Trucks: 52,000 lbs. GVWR Semi Tractor 4x6	Freightliner M2	112	https://www.myvendorlink.com/external/award?s=152477&i=51
52	Cab and Chassis Trucks: 52,000 lbs. GVWR Semi Tractor 4x6	International HV	613	https://www.myvendorlink.com/external/award?s=152477&i=52
53	Cab and Chassis Trucks: 52,000 lbs. GVWR Semi Tractor 4x6	International HX	62F	https://www.myvendorlink.com/external/award?s=152477&i=53
54	Cab and Chassis Trucks: 52,000 lbs. GVWR Semi Tractor 4x6	Kenworth T880	T880	https://www.myvendorlink.com/external/award?s=152477&i=54
55	Cab and Chassis Trucks: 52,000 lbs. GVWR Semi Tractor 4x6	Mack AN or G Series	AN or G Series	https://www.myvendorlink.com/external/award?s=152477&i=55
56	Cab and Chassis Trucks: 52,000 lbs. GVWR Semi Tractor 4x6	Peterbilt 567	567	https://www.myvendorlink.com/external/award?s=152477&i=56
57	Cab and Chassis Trucks: 52,000 lbs. GVWR Semi Tractor 4x6	Volvo V Series	V Series	https://www.myvendorlink.com/external/award?s=152477&i=57
58	Cab and Chassis Trucks: 52,000 lbs. GVWR Semi Tractor 4x6	Western Star 47X	47X	https://www.myvendorlink.com/external/award?s=152477&i=58
59	Cab and Chassis Trucks: 52,000 lbs. GVWR Truck 4x6	Freightliner M2	112	https://www.myvendorlink.com/external/award?s=152477&i=59
60	Cab and Chassis Trucks: 52,000 lbs. GVWR Truck 4x6	International HX	62F	https://www.myvendorlink.com/external/award?s=152477&i=60
61	Cab and Chassis Trucks: 52,000 lbs. GVWR Truck 4x6	International HV	613	https://www.myvendorlink.com/external/award?s=152477&i=61
62	Cab and Chassis Trucks: 52,000 lbs. GVWR Truck 4x6	Kenworth T880	T880	https://www.myvendorlink.com/external/award?s=152477&i=62
63	Cab and Chassis Trucks: 52,000 lbs. GVWR Truck 4x6	Mack AN or G Series	AN or G Series	https://www.myvendorlink.com/external/award?s=152477&i=63
64	Cab and Chassis Trucks: 52,000 lbs. GVWR Truck 4x6	Peterbilt 5671	5671	https://www.myvendorlink.com/external/award?s=152477&i=64
65	Cab and Chassis Trucks: 52,000 lbs. GVWR Truck 4x6	Volvo V Series	V Series	https://www.myvendorlink.com/external/award?s=152477&i=65
66	Cab and Chassis Trucks: 52,000 lbs. GVWR Truck 4x6	Western Star 49X	49X	https://www.myvendorlink.com/external/award?s=152477&i=66
67	Cab and Chassis: Tilt Cab (DRW) 4x2	Battle Motors LNT	LNT-21	https://www.myvendorlink.com/external/award?s=152477&i=67
68	Cab and Chassis: Tilt Cab (DRW) 4x2	Isuzu NPR-HD	N3F1	https://www.myvendorlink.com/external/award?s=152477&i=68
69	Cab and Chassis: Tilt Cab (DRW) 4x2	Isuzu FTR Chassis	MT1/61	https://www.myvendorlink.com/external/award?s=152477&i=69
70	Cab and Chassis: Tilt Cab (DRW) 4x2	Kenworth K270	K270	https://www.myvendorlink.com/external/award?s=152477&i=70
71	Cab and Chassis: Tilt Cab (DRW) 4x2	Peterbilt 2201	220	https://www.myvendorlink.com/external/award?s=152477&i=71
76	Mobile Command Unit/Critical Response Unit	Frontline Communications CRU-22	CRU-22	https://www.myvendorlink.com/external/award?s=152477&i=76

78	Refuse Truck Electric: 60,000 lbs. GVWR 4x6 (cab and chassis only)	Battle Motors LET II	LET II	https://www.myvendorlink.com/external/award?s=152477&i=78
80	Refuse Truck Electric: 60,000 lbs. GVWR 4x6 (cab and chassis only)	Mack Mack LR Electric	Mack LR Electric	https://www.myvendorlink.com/external/award?s=152477&i=80
81	Refuse Truck Electric: 60,000 lbs. GVWR 4x6 (cab and chassis only)	Peterbilt 520EV	520EV	https://www.myvendorlink.com/external/award?s=152477&i=81
82	Refuse Truck: 60,000 lbs. GVWR 4x6 (cab and chassis only)	Autocar ACX64	ACX64	https://www.myvendorlink.com/external/award?s=152477&i=82
83	Refuse Truck: 60,000 lbs. GVWR 4x6 (cab and chassis only)	Battle Motors LET2	LET2-44	https://www.myvendorlink.com/external/award?s=152477&i=83
85	Refuse Truck: 60,000 lbs. GVWR 4x6 (cab and chassis only)	Mack TE Series	TE Series	https://www.myvendorlink.com/external/award?s=152477&i=85
86	Refuse Truck: 60,000 lbs. GVWR 4x6 (cab and chassis only)	Peterbilt 520	520	https://www.myvendorlink.com/external/award?s=152477&i=86
87	Refuse Truck: Compact 9.5 Cubic Yds. Self-Loading Refuse Truck	Broyhill TD3.6	TD3.6	https://www.myvendorlink.com/external/award?s=152477&i=87
88	Tactical Armored Vehicles	Terradyne Gurkha MPV	Gurkha MPV	https://www.myvendorlink.com/external/award?s=152477&i=88
89	Terminal Tractor	Autocar ACTT42	ACTT42	https://www.myvendorlink.com/external/award?s=152477&i=89
90	Terminal Tractor	Kalmar Ottawa T2	71056	https://www.myvendorlink.com/external/award?s=152477&i=90
91	Terminal Tractor	Kalmar Ottawa T2 4x2 Offroad	71055	https://www.myvendorlink.com/external/award?s=152477&i=91
92	Terminal Tractor	Tico Pro-Spotter	Pro-Spotter	https://www.myvendorlink.com/external/award?s=152477&i=92
93	Buses: 14 to 25 Passenger Capacity Range, Van-Type Cutaway Chassis	StarTrans The Senator II	Senator SII 22	https://www.myvendorlink.com/external/award?s=152477&i=93
94	Buses: 20 to 52 Passenger Capacity Range, Conventional Truck-Type Cutaway Chassis	StarTrans The Senator II HD	Senator HD 28	https://www.myvendorlink.com/external/award?s=152477&i=94

FSA Cooperative Purchasing Program



FSA23-VEH21.0: Heavy Trucks & Buses Final Award Report

Bid Award

Contract: FSA23-VEH21.0, Heavy Trucks and Buses

Group: Buses Electric: 19 to 20 Passenger Capacity Range, Van-Type Cutaway Chassis

Item: 1, Endera, B-Series, B-Series

Description: Refer to Item Group Specifications PDF document for FSA Base Specifications.

Model Upgrade/Downgrade:

Zone	Rank	Vendor	Price	Build File	Options File
Western	Primary	Florida Transportation Systems, Inc.	\$310,740.00	Build	Options
	Alternate	Creative Bus Sales, Inc.	\$317,189.00	Build	Options
Northern	Primary	Florida Transportation Systems, Inc.	\$310,740.00	Build	Options
	Alternate	Creative Bus Sales, Inc.	\$317,189.00	Build	Options
Central	Primary	Florida Transportation Systems, Inc.	\$310,740.00	Build	Options
	Alternate	Creative Bus Sales, Inc.	\$317,189.00	Build	Options
Southern	Primary	Florida Transportation Systems, Inc.	\$310,740.00	Build	Options
	Alternate	Creative Bus Sales, Inc.	\$317,189.00	Build	Options

Bid Award

Contract: FSA23-VEH21.0, Heavy Trucks and Buses

Group: Buses Electric: 20 to 52 Passenger Capacity Range, Conventional-Type Chassis

Item: 2, Bluebird, Vision Electric, Vision Electric

Description: Refer to Item Group Specifications PDF document for FSA Base Specifications.

Model Upgrade/Downgrade:

Zone	Rank	Vendor	Price	Build File	Options File
Western	Primary	Florida Transportation Systems, Inc.	\$403,309.00	Build	Options
Northern	Primary	Florida Transportation Systems, Inc.	\$403,309.00	Build	Options
Central	Primary	Florida Transportation Systems, Inc.	\$403,309.00	Build	Options
Southern	Primary	Florida Transportation Systems, Inc.	\$403,309.00	Build	Options

Bid Award

Contract: FSA23-VEH21.0, Heavy Trucks and Buses

Group: Buses Electric: 20 to 52 Passenger Capacity Range, Conventional-Type Chassis

Item: 3, Bluebird, All-American Electric, T3RE

Description: Refer to Item Group Specifications PDF document for FSA Base Specifications.

Model Upgrade/Downgrade:

Zone	Rank	Vendor	Price	Build File	Options File
Western	Primary	Florida Transportation Systems, Inc.	\$421,854.00	Build	Options
Northern	Primary	Florida Transportation Systems, Inc.	\$421,854.00	Build	Options
Central	Primary	Florida Transportation Systems, Inc.	\$421,854.00	Build	Options
Southern	Primary	Florida Transportation Systems, Inc.	\$421,854.00	Build	Options

Bid Award

Contract: FSA23-VEH21.0, Heavy Trucks and Buses

Group: Buses Electric: 20 to 52 Passenger Capacity Range, Conventional-Type Chassis

Item: 5, Phoenix Motorcars, Z600 Type A School Bus, Z600

Description: Refer to Item Group Specifications PDF document for FSA Base Specifications.

Model Upgrade/Downgrade:

Zone	Rank	Vendor	Price	Build File	Options File
Western	Primary	Phoenix Motorcars Leasing LLC	\$271,450.00	Build	Options
Northern	Primary	Phoenix Motorcars Leasing LLC	\$271,450.00	Build	Options
Central	Primary	Phoenix Motorcars Leasing LLC	\$271,450.00	Build	Options
Southern	Primary	Phoenix Motorcars Leasing LLC	\$271,450.00	Build	Options

Bid Award

Contract: FSA23-VEH21.0, Heavy Trucks and Buses

Group: Buses Electric: 44 To 80 Passenger Capacity Range, Commercial-Type Chassis

Item: 6, BYD, The Dreamer, Type D Electric School Bus

Description: Refer to Item Group Specifications PDF document for FSA Base Specifications.

Model Upgrade/Downgrade:

Zone	Rank	Vendor	Price	Build File	Options File
Western	Primary	Creative Bus Sales, Inc.	\$437,332.00	Build	Options
Northern	Primary	Creative Bus Sales, Inc.	\$437,332.00	Build	Options
Central	Primary	Creative Bus Sales, Inc.	\$437,332.00	Build	Options
Southern	Primary	Creative Bus Sales, Inc.	\$437,332.00	Build	Options

Bid Award

Contract: FSA23-VEH21.0, Heavy Trucks and Buses

Group: Buses: 14 to 25 Passenger Capacity Range, Van-Type Cutaway Chassis

Item: 7, Endera, B-Series, B-Series

Description: Refer to Item Group Specifications PDF document for FSA Base Specifications.

Model Upgrade/Downgrade:

Zone	Rank	Vendor	Price	Build File	Options File
Western	Primary	Florida Transportation Systems, Inc.	\$118,877.00	Build	Options
Northern	Primary	Florida Transportation Systems, Inc.	\$118,877.00	Build	Options
Central	Primary	Florida Transportation Systems, Inc.	\$118,877.00	Build	Options
Southern	Primary	Florida Transportation Systems, Inc.	\$118,877.00	Build	Options

Bid Award

Contract: FSA23-VEH21.0, Heavy Trucks and Buses

Group: Buses: 14 to 25 Passenger Capacity Range, Van-Type Cutaway Chassis

Item: 8, Starcraft, Allstar, Allstar

Description: Refer to Item Group Specifications PDF document for FSA Base Specifications.

Model Upgrade/Downgrade:

Zone	Rank	Vendor	Price	Build File	Options File
Western	Primary	Creative Bus Sales, Inc.	\$79,085.00	Build	Options
Northern	Primary	Creative Bus Sales, Inc.	\$79,085.00	Build	Options
Central	Primary	Creative Bus Sales, Inc.	\$79,085.00	Build	Options
Southern	Primary	Creative Bus Sales, Inc.	\$79,085.00	Build	Options

Bid Award

Contract: FSA23-VEH21.0, Heavy Trucks and Buses

Group: Buses: 14 to 25 Passenger Capacity Range, Van-Type Cutaway Chassis

Item: 93, StarTrans, The Senator II, Senator SII 22

Description: Refer to Item Group Specifications PDF document for FSA Base Specifications.

Model Upgrade/Downgrade:

Zone	Rank	Vendor	Price	Build File	Options File
Western	Primary	Matthews Bus Alliance Inc.	\$102,622.00	Build	Options
Northern	Primary	Matthews Bus Alliance Inc.	\$102,622.00	Build	Options
Central	Primary	Matthews Bus Alliance Inc.	\$102,622.00	Build	Options
Southern	Primary	Matthews Bus Alliance Inc.	\$102,622.00	Build	Options

Bid Award

Contract: FSA23-VEH21.0, Heavy Trucks and Buses

Group: Buses: 20 to 52 Passenger Capacity Range, Conventional Truck-Type Cutaway Chassis

Item: 9, Bluebird, Vision, Vision

Description: Refer to Item Group Specifications PDF document for FSA Base Specifications.

Model Upgrade/Downgrade:

Zone	Rank	Vendor	Price	Build File	Options File
Western	Primary	Florida Transportation Systems, Inc.	\$143,750.00	Build	Options
Northern	Primary	Florida Transportation Systems, Inc.	\$143,450.00	Build	Options
Central	Primary	Florida Transportation Systems, Inc.	\$143,450.00	Build	Options
Southern	Primary	Florida Transportation Systems, Inc.	\$143,750.00	Build	Options

Bid Award

Contract: FSA23-VEH21.0, Heavy Trucks and Buses

Group: Buses: 20 to 52 Passenger Capacity Range, Conventional Truck-Type Cutaway Chassis

Item: 11, Starcraft, Allstar, Allstar

Description: Refer to Item Group Specifications PDF document for FSA Base Specifications.

Model Upgrade/Downgrade:

Zone	Rank	Vendor	Price	Build File	Options File
Western	Primary	Creative Bus Sales, Inc.	\$140,137.00	Build	Options
Northern	Primary	Creative Bus Sales, Inc.	\$140,137.00	Build	Options
Central	Primary	Creative Bus Sales, Inc.	\$140,137.00	Build	Options
Southern	Primary	Creative Bus Sales, Inc.	\$140,137.00	Build	Options

Bid Award

Contract: FSA23-VEH21.0, Heavy Trucks and Buses

Group: Buses: 20 to 52 Passenger Capacity Range, Conventional Truck-Type Cutaway Chassis

Item: 94, StarTrans, The Senator II HD, Senator HD 28

Description: Refer to Item Group Specifications PDF document for FSA Base Specifications.

Model Upgrade/Downgrade:

Zone	Rank	Vendor	Price	Build File	Options File
Western	Primary	Matthews Bus Alliance Inc.	\$147,140.00	Build	Options
Northern	Primary	Matthews Bus Alliance Inc.	\$147,140.00	Build	Options
Central	Primary	Matthews Bus Alliance Inc.	\$147,140.00	Build	Options
Southern	Primary	Matthews Bus Alliance Inc.	\$147,140.00	Build	Options

Bid Award

Contract: FSA23-VEH21.0, Heavy Trucks and Buses

Group: Buses: 33 to 54 Passenger Capacity Range, Commercial-Type, Rear Engine Chassis

Item: 12, Bluebird, T3RE, T3RE

Description: Refer to Item Group Specifications PDF document for FSA Base Specifications.

Model Upgrade/Downgrade:

Zone	Rank	Vendor	Price	Build File	Options File
Western	Primary	Florida Transportation Systems, Inc.	\$175,832.00	Build	Options
Northern	Primary	Florida Transportation Systems, Inc.	\$175,532.00	Build	Options
Central	Primary	Florida Transportation Systems, Inc.	\$175,532.00	Build	Options
Southern	Primary	Florida Transportation Systems, Inc.	\$175,832.00	Build	Options

Bid Award

Contract: FSA23-VEH21.0, Heavy Trucks and Buses

Group: Buses: 36 to 52 Passenger Capacity Range, Commercial-Type, Front Engine Chassis

Item: 13, Bluebird, T3FE, T3FE

Description: Refer to Item Group Specifications PDF document for FSA Base Specifications.

Model Upgrade/Downgrade:

Zone	Rank	Vendor	Price	Build File	Options File
Western	Primary	Florida Transportation Systems, Inc.	\$157,829.00	Build	
Northern	Primary	Florida Transportation Systems, Inc.	\$157,629.00	Build	
Central	Primary	Florida Transportation Systems, Inc.	\$157,629.00	Build	
Southern	Primary	Florida Transportation Systems, Inc.	\$157,829.00	Build	

Bid Award

Contract: FSA23-VEH21.0, Heavy Trucks and Buses

Group: Cab and Chassis Trucks Electric: 54,000 lbs. GVWR 4x6 Semi Tractor

Item: 14, Kenworth, T680E, T680E

Description: Refer to Item Group Specifications PDF document for FSA Base Specifications.

Model Upgrade/Downgrade:

Zone	Rank	Vendor	Price	Build File	Options File
Western					
Northern	Primary	Kenworth of Jacksonville	\$467,936.00	Build	Options
Central	Primary	Florida Kenworth, LLC	\$471,912.00	Build	Options
	Alternate	All Roads Kenworth, LLC.	\$500,286.00	Build	Options
Southern	Primary	Florida Kenworth, LLC	\$471,912.00	Build	Options
	Alternate	All Roads Kenworth, LLC.	\$500,286.00	Build	Options

Bid Award

Contract: FSA23-VEH21.0, Heavy Trucks and Buses

Group: Cab and Chassis Trucks Electric: 54,000 lbs. GVWR 4x6 Semi Tractor

Item: 15, Peterbilt, 579EV, 579EV

Description: Refer to Item Group Specifications PDF document for FSA Base Specifications.

Model Upgrade/Downgrade:

Zone	Rank	Vendor	Price	Build File	Options File
Western	Primary	Rush Truck Centers of Florida, Inc.	\$516,074.00	Build	Options
Northern	Primary	Rush Truck Centers of Florida, Inc.	\$516,074.00	Build	Options
Central	Primary	Rush Truck Centers of Florida, Inc.	\$516,074.00	Build	Options
Southern	Primary	The Peterbilt Store South Florida LLC	\$484,000.00	Build	Options

Bid Award

Contract: FSA23-VEH21.0, Heavy Trucks and Buses

Group: Cab and Chassis Trucks Electric: 54,000 lbs. GVWR 4x6 Semi Tractor

Item: 16, Volvo, VNR, VNR

Description: Refer to Item Group Specifications PDF document for FSA Base Specifications.

Model Upgrade/Downgrade:

Zone	Rank	Vendor	Price	Build File	Options File
Western	Primary	Nextran Truck Centers	\$409,688.00	Build	Options
Northern	Primary	Nextran Truck Centers	\$409,688.00	Build	Options
Central	Primary	Nextran Truck Centers	\$409,688.00	Build	Options
Southern	Primary	Nextran Truck Centers	\$409,688.00	Build	Options

Bid Award

Contract: FSA23-VEH21.0, Heavy Trucks and Buses

Group: Cab and Chassis Trucks Electric: Conventional Cab 33,000 lbs. GVWR (DRW) 4x2

Item: 18, International, EMV, MV60E

Description: Refer to Item Group Specifications PDF document for FSA Base Specifications.

Model Upgrade/Downgrade:

Zone	Rank	Vendor	Price	Build File	Options File
Western	Primary	Cumberland International Trucks of Florida	\$272,000.00	Build	Options
Northern	Primary	Cumberland International Trucks of Florida	\$270,000.00	Build	Options
Central	Primary	Cumberland International Trucks of Florida	\$270,000.00	Build	Options
	Alternate	Sun State International Trucks	\$270,250.00	Build	Options
Southern	Primary	Rechtien International Trucks	\$270,677.00	Build	Options

Bid Award

Contract: FSA23-VEH21.0, Heavy Trucks and Buses

Group: Cab and Chassis Trucks Electric: Conventional Cab 33,000 lbs. GVWR (DRW) 4x2

Item: 19, Mack, MD7 Electric, MDe7

Description: Refer to Item Group Specifications PDF document for FSA Base Specifications.

Model Upgrade/Downgrade:

Zone	Rank	Vendor	Price	Build File	Options File
Western	Primary	Nextran Truck Centers	\$242,926.00	Build	Options
Northern	Primary	Nextran Truck Centers	\$242,926.00	Build	Options
Central	Primary	Nextran Truck Centers	\$242,926.00	Build	Options
Southern	Primary	Nextran Truck Centers	\$242,926.00	Build	Options

Bid Award

Contract: FSA23-VEH21.0, Heavy Trucks and Buses

Group: Cab and Chassis Trucks Electric: Tilt Cab 26,000 lbs. GVWR (DRW) 4x2

Item: 20, Battle Motors, LNT, LNT

Description: Refer to Item Group Specifications PDF document for FSA Base Specifications.

Model Upgrade/Downgrade:

Zone	Rank	Vendor	Price	Build File	Options File
Western	Primary	All Roads Kenworth, LLC.	\$428,600.00	Build	Options
	Alternate	Container Systems & Equipment Co., Inc.	\$437,500.00	Build	Options
	Alternate	TRUCKMAX, INC.	\$536,127.00	Build	Options
Northern	Primary	All Roads Kenworth, LLC.	\$426,600.00	Build	Options
	Alternate	Container Systems & Equipment Co., Inc.	\$437,500.00	Build	Options
	Alternate	TRUCKMAX, INC.	\$536,127.00	Build	Options
Central	Primary	Container Systems & Equipment Co., Inc.	\$437,500.00	Build	Options
	Alternate	TRUCKMAX, INC.	\$536,127.00	Build	Options
Southern	Primary	All Roads Kenworth, LLC.	\$423,600.00	Build	Options
	Alternate	TRUCKMAX, INC.	\$536,127.00	Build	Options

Bid Award

Contract: FSA23-VEH21.0, Heavy Trucks and Buses

Group: Cab and Chassis Trucks Electric: Tilt Cab 26,000 lbs. GVWR (DRW) 4x2

Item: 21, Peterbilt, 220EV, 220

Description: Refer to Item Group Specifications PDF document for FSA Base Specifications.

Model Upgrade/Downgrade:

Zone	Rank	Vendor	Price	Build File	Options File
Western	Primary	Rush Truck Centers of Florida, Inc.	\$360,338.00	Build	Options
Northern	Primary	Rush Truck Centers of Florida, Inc.	\$360,338.00	Build	Options
Central	Primary	Rush Truck Centers of Florida, Inc.	\$360,338.00	Build	Options
Southern	Primary	The Peterbilt Store South Florida LLC	\$358,082.00	Build	Options

Bid Award

Contract: FSA23-VEH21.0, Heavy Trucks and Buses

Group: Cab and Chassis Trucks: 17,500 lbs. GVWR (DRW) 4x2

Item: 23, Ford, F-550 Crew Cab, W5G

Description: Refer to Item Group Specifications PDF document for FSA Base Specifications.

Model Upgrade/Downgrade:

Zone	Rank	Vendor	Price	Build File	Options File
Western	Primary	Bachrodt FT, LLC dba Palmetto Ford of Miami	\$60,305.00	Build	Options
	Alternate	Duval Ford LLC	\$60,569.00	Build	Options
Northern	Primary	Bachrodt FT, LLC dba Palmetto Ford of Miami	\$60,080.00	Build	Options
	Alternate	Duval Ford LLC	\$60,359.00	Build	Options
Central	Primary	Bachrodt FT, LLC dba Palmetto Ford of Miami	\$59,855.00	Build	Options
	Alternate	Duval Ford LLC	\$60,449.00	Build	Options
Southern	Primary	Bachrodt FT, LLC dba Palmetto Ford of Miami	\$59,855.00	Build	Options
	Alternate	Duval Ford LLC	\$60,594.00	Build	Options

Bid Award

Contract: FSA23-VEH21.0, Heavy Trucks and Buses

Group: Cab and Chassis Trucks: 17,500 lbs. GVWR (DRW) 4x2

Item: 24, Ford, F-550 Super Cab, X5G

Description: Refer to Item Group Specifications PDF document for FSA Base Specifications.

Model Upgrade/Downgrade:

Zone	Rank	Vendor	Price	Build File	Options File
Western	Primary	Bachrodt FT, LLC dba Palmetto Ford of Miami	\$59,905.00	Build	Options
	Alternate	Duval Ford LLC	\$60,166.00	Build	Options
Northern	Primary	Bachrodt FT, LLC dba Palmetto Ford of Miami	\$59,680.00	Build	Options
	Alternate	Duval Ford LLC	\$59,956.00	Build	Options
Central	Primary	Bachrodt FT, LLC dba Palmetto Ford of Miami	\$59,455.00	Build	Options
	Alternate	Duval Ford LLC	\$60,046.00	Build	Options
Southern	Primary	Bachrodt FT, LLC dba Palmetto Ford of Miami	\$59,455.00	Build	Options
	Alternate	Duval Ford LLC	\$60,191.00	Build	Options

Bid Award

Contract: FSA23-VEH21.0, Heavy Trucks and Buses

Group: Cab and Chassis Trucks: 17,500 lbs. GVWR (DRW) 4x2

Item: 25, Ford, F-600 Super Cab, F6K

Description: Refer to Item Group Specifications PDF document for FSA Base Specifications.

Model Upgrade/Downgrade:

Zone	Rank	Vendor	Price	Build File	Options File
Western	Primary	Bachrodt FT, LLC dba Palmetto Ford of Miami	\$61,492.00	Build	Options
	Alternate	Duval Ford LLC	\$61,765.00	Build	Options
Northern	Primary	Bachrodt FT, LLC dba Palmetto Ford of Miami	\$61,267.00	Build	Options
	Alternate	Duval Ford LLC	\$61,555.00	Build	Options
Central	Primary	Bachrodt FT, LLC dba Palmetto Ford of Miami	\$61,042.00	Build	Options
	Alternate	Duval Ford LLC	\$61,645.00	Build	Options
Southern	Primary	Bachrodt FT, LLC dba Palmetto Ford of Miami	\$61,042.00	Build	Options
	Alternate	Duval Ford LLC	\$61,790.00	Build	Options

Bid Award

Contract: FSA23-VEH21.0, Heavy Trucks and Buses

Group: Cab and Chassis Trucks: 17,500 lbs. GVWR (DRW) 4x2

Item: 26, Ford, F-550 Regular Cab, F5G

Description: Refer to Item Group Specifications PDF document for FSA Base Specifications.

Model Upgrade/Downgrade:

Zone	Rank	Vendor	Price	Build File	Options File
Western	Primary	Duval Ford LLC	\$58,437.00	Build	Options
Northern	Primary	Duval Ford LLC	\$58,227.00	Build	Options
Central	Primary	Duval Ford LLC	\$58,317.00	Build	Options
Southern	Primary	Duval Ford LLC	\$58,462.00	Build	Options

Bid Award

Contract: FSA23-VEH21.0, Heavy Trucks and Buses

Group: Cab and Chassis Trucks: 17,500 lbs. GVWR (DRW) 4x2

Item: 27, International, CV, 515

Description: Refer to Item Group Specifications PDF document for FSA Base Specifications.

Model Upgrade/Downgrade:

Zone	Rank	Vendor	Price	Build File	Options File
Western	Primary	Cumberland International Trucks of Florida	\$67,400.00	Build	Options
Northern	Primary	Cumberland International Trucks of Florida	\$66,400.00	Build	Options
Central	Primary	Sun State International Trucks	\$66,275.00	Build	Options
	Alternate	Cumberland International Trucks of Florida	\$66,400.00	Build	Options
Southern	Primary	Rechtien International Trucks	\$66,373.00	Build	Options

Bid Award

Contract: FSA23-VEH21.0, Heavy Trucks and Buses

Group: Cab and Chassis Trucks: 17,500 lbs. GVWR (DRW) 4x2

Item: 28, Kenworth, T180, T180

Description: Refer to Item Group Specifications PDF document for FSA Base Specifications.

Model Upgrade/Downgrade:

Zone	Rank	Vendor	Price	Build File	Options File
Western					
Northern	Primary	Kenworth of Jacksonville	\$95,559.00	Build	Options
Central	Primary	All Roads Kenworth, LLC.	\$95,909.00	Build	Options
Southern	Primary	All Roads Kenworth, LLC.	\$95,909.00	Build	Options

Bid Award

Contract: FSA23-VEH21.0, Heavy Trucks and Buses

Group: Cab and Chassis Trucks: 17,500 lbs. GVWR (DRW) 4x2

Item: 29, Peterbilt, 535, 535

Description: Refer to Item Group Specifications PDF document for FSA Base Specifications.

Model Upgrade/Downgrade:

Zone	Rank	Vendor	Price	Build File	Options File
Western	Primary	Rush Truck Centers of Florida, Inc.	\$104,352.00	Build	Options
Northern	Primary	Rush Truck Centers of Florida, Inc.	\$104,352.00	Build	Options
Central	Primary	Rush Truck Centers of Florida, Inc.	\$104,352.00	Build	Options
Southern	Primary	The Peterbilt Store South Florida LLC	\$106,067.00	Build	Options

Bid Award

Contract: FSA23-VEH21.0, Heavy Trucks and Buses

Group: Cab and Chassis Trucks: 17,500 lbs. GVWR (DRW) 4x4

Item: 31, Ford, F-550 Super Cab, X5H

Description: Refer to Item Group Specifications PDF document for FSA Base Specifications.

Model Upgrade/Downgrade:

Zone	Rank	Vendor	Price	Build File	Options File
Western	Primary	Bachrodt FT, LLC dba Palmetto Ford of Miami	\$62,665.00	Build	Options
	Alternate	Duval Ford LLC	\$62,788.00	Build	Options
Northern	Primary	Bachrodt FT, LLC dba Palmetto Ford of Miami	\$62,440.00	Build	Options
	Alternate	Duval Ford LLC	\$62,578.00	Build	Options
Central	Primary	Bachrodt FT, LLC dba Palmetto Ford of Miami	\$62,215.00	Build	Options
	Alternate	Duval Ford LLC	\$62,668.00	Build	Options
Southern	Primary	Bachrodt FT, LLC dba Palmetto Ford of Miami	\$62,215.00	Build	Options
	Alternate	Duval Ford LLC	\$62,813.00	Build	Options

Bid Award

Contract: FSA23-VEH21.0, Heavy Trucks and Buses

Group: Cab and Chassis Trucks: 17,500 lbs. GVWR (DRW) 4x4

Item: 32, Ford, F-550 Crew Cab, W5H

Description: Refer to Item Group Specifications PDF document for FSA Base Specifications.

Model Upgrade/Downgrade:

Zone	Rank	Vendor	Price	Build File	Options File
Western	Primary	Bachrodt FT, LLC dba Palmetto Ford of Miami	\$63,464.00	Build	Options
	Alternate	Duval Ford LLC	\$63,752.00	Build	Options
Northern	Primary	Bachrodt FT, LLC dba Palmetto Ford of Miami	\$63,239.00	Build	Options
	Alternate	Duval Ford LLC	\$63,542.00	Build	Options
Central	Primary	Bachrodt FT, LLC dba Palmetto Ford of Miami	\$63,014.00	Build	Options
	Alternate	Duval Ford LLC	\$63,632.00	Build	Options
Southern	Primary	Bachrodt FT, LLC dba Palmetto Ford of Miami	\$63,014.00	Build	Options
	Alternate	Duval Ford LLC	\$63,777.00	Build	Options

Bid Award

Contract: FSA23-VEH21.0, Heavy Trucks and Buses

Group: Cab and Chassis Trucks: 17,500 lbs. GVWR (DRW) 4x4

Item: 33, Ford, F-550 Regular Cab, F5H

Description: Refer to Item Group Specifications PDF document for FSA Base Specifications.

Model Upgrade/Downgrade:

Zone	Rank	Vendor	Price	Build File	Options File
Western	Primary	Bachrodt FT, LLC dba Palmetto Ford of Miami	\$60,810.00	Build	Options
	Alternate	Duval Ford LLC	\$61,078.00	Build	Options
Northern	Primary	Bachrodt FT, LLC dba Palmetto Ford of Miami	\$60,585.00	Build	Options
	Alternate	Duval Ford LLC	\$60,868.00	Build	Options
Central	Primary	Bachrodt FT, LLC dba Palmetto Ford of Miami	\$60,360.00	Build	Options
	Alternate	Duval Ford LLC	\$60,958.00	Build	Options
Southern	Primary	Bachrodt FT, LLC dba Palmetto Ford of Miami	\$60,360.00	Build	Options
	Alternate	Duval Ford LLC	\$61,103.00	Build	Options

Bid Award

Contract: FSA23-VEH21.0, Heavy Trucks and Buses

Group: Cab and Chassis Trucks: 17,500 lbs. GVWR (DRW) 4x4

Item: 34, Ford, F-600 Regular Cab, F6L

Description: Refer to Item Group Specifications PDF document for FSA Base Specifications.

Model Upgrade/Downgrade:

Zone	Rank	Vendor	Price	Build File	Options File
Western	Primary	Bachrodt FT, LLC dba Palmetto Ford of Miami	\$64,113.00	Build	Options
	Alternate	Duval Ford LLC	\$64,406.00	Build	Options
Northern	Primary	Bachrodt FT, LLC dba Palmetto Ford of Miami	\$63,888.00	Build	Options
	Alternate	Duval Ford LLC	\$64,196.00	Build	Options
Central	Primary	Bachrodt FT, LLC dba Palmetto Ford of Miami	\$63,663.00	Build	Options
	Alternate	Duval Ford LLC	\$64,286.00	Build	Options
Southern	Primary	Bachrodt FT, LLC dba Palmetto Ford of Miami	\$63,663.00	Build	Options
	Alternate	Duval Ford LLC	\$64,431.00	Build	Options

Bid Award

Contract: FSA23-VEH21.0, Heavy Trucks and Buses

Group: Cab and Chassis Trucks: 17,500 lbs. GVWR (DRW) 4x4

Item: 35, International, CV, 515

Description: Refer to Item Group Specifications PDF document for FSA Base Specifications.

Model Upgrade/Downgrade:

Zone	Rank	Vendor	Price	Build File	Options File
Western	Primary	Cumberland International Trucks of Florida	\$71,000.00	Build	Options
Northern	Primary	Cumberland International Trucks of Florida	\$69,995.00	Build	Options
Central	Primary	Sun State International Trucks	\$69,875.00	Build	Options
	Alternate	Cumberland International Trucks of Florida	\$69,995.00	Build	Options
Southern	Primary	Rechtien International Trucks	\$70,178.00	Build	Options

Bid Award

Contract: FSA23-VEH21.0, Heavy Trucks and Buses

Group: Cab and Chassis Trucks: 25,500 lbs. GVWR (DRW) 4x2

Item: 36, Ford, F-650 Regular Cab, F6D

Description: Refer to Item Group Specifications PDF document for FSA Base Specifications.

Model Upgrade/Downgrade:

Zone	Rank	Vendor	Price	Build File	Options File
Western	Primary	Bachrodt FT, LLC dba Palmetto Ford of Miami	\$68,547.00	Build	Options
	Alternate	BOZARD FORD	\$70,751.00	Build	Options
Northern	Primary	Bachrodt FT, LLC dba Palmetto Ford of Miami	\$67,547.00	Build	Options
	Alternate	BOZARD FORD	\$70,751.00	Build	Options
Central	Primary	Bachrodt FT, LLC dba Palmetto Ford of Miami	\$67,547.00	Build	Options
	Alternate	BOZARD FORD	\$70,751.00	Build	Options
Southern	Primary	Bachrodt FT, LLC dba Palmetto Ford of Miami	\$67,547.00	Build	Options
	Alternate	BOZARD FORD	\$70,751.00	Build	Options

Bid Award

Contract: FSA23-VEH21.0, Heavy Trucks and Buses

Group: Cab and Chassis Trucks: 25,500 lbs. GVWR (DRW) 4x2

Item: 37, Freightliner, M2, 106

Description: Refer to Item Group Specifications PDF document for FSA Base Specifications.

Model Upgrade/Downgrade:

Zone	Rank	Vendor	Price	Build File	Options File
Western	Primary	SBL Freightliner, LLC	\$76,300.00	Build	Options
	Alternate	Tampa Truck Center	\$77,529.00	Build	Options
Northern	Primary	SBL Freightliner, LLC	\$76,900.00	Build	Options
	Alternate	Tampa Truck Center	\$77,529.00	Build	Options
Central	Primary	SBL Freightliner, LLC	\$76,300.00	Build	Options
	Alternate	Tampa Truck Center	\$77,529.00	Build	Options
Southern	Primary	SBL Freightliner, LLC	\$75,900.00	Build	Options
	Alternate	Tampa Truck Center	\$77,529.00	Build	Options

Bid Award

Contract: FSA23-VEH21.0, Heavy Trucks and Buses

Group: Cab and Chassis Trucks: 25,500 lbs. GVWR (DRW) 4x2

Item: 38, Hino, L6, L6

Description: Refer to Item Group Specifications PDF document for FSA Base Specifications.

Model Upgrade/Downgrade:

Zone	Rank	Vendor	Price	Build File	Options File
Western	Primary	TRUCKMAX, INC.	\$76,024.00	Build	Options
Northern	Primary	TRUCKMAX, INC.	\$76,024.00	Build	Options
	Alternate	Nextran Truck Centers	\$80,036.00	Build	Options
Central	Primary	TRUCKMAX, INC.	\$76,024.00	Build	Options
Southern	Primary	TRUCKMAX, INC.	\$76,024.00	Build	Options

Bid Award

Contract: FSA23-VEH21.0, Heavy Trucks and Buses

Group: Cab and Chassis Trucks: 25,500 lbs. GVWR (DRW) 4x2

Item: 39, International, MV, 607

Description: Refer to Item Group Specifications PDF document for FSA Base Specifications.

Model Upgrade/Downgrade:

Zone	Rank	Vendor	Price	Build File	Options File
Western	Primary	Cumberland International Trucks of Florida	\$80,500.00	Build	Options
Northern	Primary	Cumberland International Trucks of Florida	\$79,500.00	Build	Options
Central	Primary	Sun State International Trucks	\$79,425.00	Build	Options
	Alternate	Cumberland International Trucks of Florida	\$79,500.00	Build	Options
Southern	Primary	Rechtien International Trucks	\$79,964.00	Build	Options

Bid Award

Contract: FSA23-VEH21.0, Heavy Trucks and Buses

Group: Cab and Chassis Trucks: 25,500 lbs. GVWR (DRW) 4x2

Item: 40, Kenworth, T280, T280

Description: Refer to Item Group Specifications PDF document for FSA Base Specifications.

Model Upgrade/Downgrade:

Zone	Rank	Vendor	Price	Build File	Options File
Western					
Northern	Primary	Kenworth of Jacksonville	\$102,073.00	Build	Options
Central	Primary	All Roads Kenworth, LLC.	\$97,413.00	Build	Options
	Alternate	Florida Kenworth, LLC	\$98,667.00	Build	Options
Southern	Primary	All Roads Kenworth, LLC.	\$97,413.00	Build	Options
	Alternate	Florida Kenworth, LLC	\$98,667.00	Build	Options

Bid Award

Contract: FSA23-VEH21.0, Heavy Trucks and Buses

Group: Cab and Chassis Trucks: 25,500 lbs. GVWR (DRW) 4x2

Item: 41, Mack, MD6, MD6

Description: Refer to Item Group Specifications PDF document for FSA Base Specifications.

Model Upgrade/Downgrade:

Zone	Rank	Vendor	Price	Build File	Options File
Western	Primary	Nextran Truck Centers	\$83,676.00	Build	Options
Northern	Primary	Nextran Truck Centers	\$83,676.00	Build	Options
Central	Primary	Nextran Truck Centers	\$83,676.00	Build	Options
Southern	Primary	Nextran Truck Centers	\$83,676.00	Build	Options

Bid Award

Contract: FSA23-VEH21.0, Heavy Trucks and Buses

Group: Cab and Chassis Trucks: 25,500 lbs. GVWR (DRW) 4x2

Item: 42, Peterbilt, 536, 536

Description: Refer to Item Group Specifications PDF document for FSA Base Specifications.

Model Upgrade/Downgrade:

Zone	Rank	Vendor	Price	Build File	Options File
Western	Primary	Rush Truck Centers of Florida, Inc.	\$107,305.00	Build	Options
Northern	Primary	Rush Truck Centers of Florida, Inc.	\$107,305.00	Build	Options
Central	Primary	Rush Truck Centers of Florida, Inc.	\$107,305.00	Build	Options
Southern	Primary	The Peterbilt Store South Florida LLC	\$109,703.00	Build	Options

Bid Award

Contract: FSA23-VEH21.0, Heavy Trucks and Buses

Group: Cab and Chassis Trucks: 30,000 lbs. GVWR (DRW) 4x2

Item: 43, Ford, F-750 Regular Cab, F7D

Description: Refer to Item Group Specifications PDF document for FSA Base Specifications.

Model Upgrade/Downgrade:

Zone	Rank	Vendor	Price	Build File	Options File
Western	Primary	Bachrodt FT, LLC dba Palmetto Ford of Miami	\$70,163.00	Build	Options
	Alternate	BOZARD FORD	\$72,136.00	Build	Options
Northern	Primary	Bachrodt FT, LLC dba Palmetto Ford of Miami	\$69,163.00	Build	Options
	Alternate	BOZARD FORD	\$72,136.00	Build	Options
Central	Primary	Bachrodt FT, LLC dba Palmetto Ford of Miami	\$69,163.00	Build	Options
	Alternate	BOZARD FORD	\$72,136.00	Build	Options
Southern	Primary	Bachrodt FT, LLC dba Palmetto Ford of Miami	\$69,163.00	Build	Options
	Alternate	BOZARD FORD	\$72,136.00	Build	Options

Bid Award

Contract: FSA23-VEH21.0, Heavy Trucks and Buses

Group: Cab and Chassis Trucks: 30,000 lbs. GVWR (DRW) 4x2

Item: 44, Freightliner, M2, 106

Description: Refer to Item Group Specifications PDF document for FSA Base Specifications.

Model Upgrade/Downgrade:

Zone	Rank	Vendor	Price	Build File	Options File
Western	Primary	Tampa Truck Center	\$77,329.00	Build	Options
	Alternate	Orlando Freightliner	\$77,354.00	Build	Options
	Alternate	SBL Freightliner, LLC	\$77,500.00	Build	Options
Northern	Primary	Orlando Freightliner	\$77,074.00	Build	Options
	Alternate	Tampa Truck Center	\$77,329.00	Build	Options
	Alternate	SBL Freightliner, LLC	\$77,900.00	Build	Options
Central	Primary	Orlando Freightliner	\$76,774.00	Build	Options
	Alternate	SBL Freightliner, LLC	\$77,300.00	Build	Options
	Alternate	Tampa Truck Center	\$77,329.00	Build	Options
Southern	Primary	SBL Freightliner, LLC	\$76,900.00	Build	Options
	Alternate	Tampa Truck Center	\$77,329.00	Build	Options
	Alternate	Orlando Freightliner	\$77,354.00	Build	Options

Bid Award

Contract: FSA23-VEH21.0, Heavy Trucks and Buses

Group: Cab and Chassis Trucks: 30,000 lbs. GVWR (DRW) 4x2

Item: 45, Hino, L7, L7

Description: Refer to Item Group Specifications PDF document for FSA Base Specifications.

Model Upgrade/Downgrade:

Zone	Rank	Vendor	Price	Build File	Options File
Western	Primary	TRUCKMAX, INC.	\$79,255.00	Build	Options
Northern	Primary	TRUCKMAX, INC.	\$79,255.00	Build	Options
	Alternate	Nextran Truck Centers	\$81,939.00	Build	Options
Central	Primary	TRUCKMAX, INC.	\$79,255.00	Build	Options
Southern	Primary	TRUCKMAX, INC.	\$79,255.00	Build	Options

Bid Award

Contract: FSA23-VEH21.0, Heavy Trucks and Buses

Group: Cab and Chassis Trucks: 30,000 lbs. GVWR (DRW) 4x2

Item: 46, International, MV, 607

Description: Refer to Item Group Specifications PDF document for FSA Base Specifications.

Model Upgrade/Downgrade:

Zone	Rank	Vendor	Price	Build File	Options File
Western	Primary	Cumberland International Trucks of Florida	\$81,950.00	Build	Options
Northern	Primary	Cumberland International Trucks of Florida	\$80,950.00	Build	Options
Central	Primary	Sun State International Trucks	\$80,875.00	Build	Options
	Alternate	Cumberland International Trucks of Florida	\$80,950.00	Build	Options
Southern	Primary	Rechtien International Trucks	\$81,255.00	Build	Options

Bid Award

Contract: FSA23-VEH21.0, Heavy Trucks and Buses

Group: Cab and Chassis Trucks: 30,000 lbs. GVWR (DRW) 4x2

Item: 47, Kenworth, T380, T380

Description: Refer to Item Group Specifications PDF document for FSA Base Specifications.

Model Upgrade/Downgrade:

Zone	Rank	Vendor	Price	Build File	Options File
Western					
Northern	Primary	Kenworth of Jacksonville	\$102,925.00	Build	Options
Central	Primary	All Roads Kenworth, LLC.	\$98,800.00	Build	Options
	Alternate	Florida Kenworth, LLC	\$101,463.00	Build	Options
Southern	Primary	All Roads Kenworth, LLC.	\$98,800.00	Build	Options
	Alternate	Florida Kenworth, LLC	\$101,463.00	Build	Options

Bid Award

Contract: FSA23-VEH21.0, Heavy Trucks and Buses

Group: Cab and Chassis Trucks: 30,000 lbs. GVWR (DRW) 4x2

Item: 48, Mack, MD7, MD7

Description: Refer to Item Group Specifications PDF document for FSA Base Specifications.

Model Upgrade/Downgrade:

Zone	Rank	Vendor	Price	Build File	Options File
Western	Primary	Nextran Truck Centers	\$88,890.00	Build	Options
Northern	Primary	Nextran Truck Centers	\$88,890.00	Build	Options
Central	Primary	Nextran Truck Centers	\$88,890.00	Build	Options
Southern	Primary	Nextran Truck Centers	\$88,890.00	Build	Options

Bid Award

Contract: FSA23-VEH21.0, Heavy Trucks and Buses

Group: Cab and Chassis Trucks: 30,000 lbs. GVWR (DRW) 4x2

Item: 49, Peterbilt, 537, 537

Description: Refer to Item Group Specifications PDF document for FSA Base Specifications.

Model Upgrade/Downgrade:

Zone	Rank	Vendor	Price	Build File	Options File
Western	Primary	Rush Truck Centers of Florida, Inc.	\$111,720.00	Build	Options
Northern	Primary	Rush Truck Centers of Florida, Inc.	\$111,720.00	Build	Options
Central	Primary	Rush Truck Centers of Florida, Inc.	\$111,720.00	Build	Options
Southern	Primary	The Peterbilt Store South Florida LLC	\$115,029.00	Build	Options

Bid Award

Contract: FSA23-VEH21.0, Heavy Trucks and Buses

Group: Cab and Chassis Trucks: 30,000 lbs. GVWR (DRW) 4x2

Item: 50, Western Star, 47X, 47X

Description: Refer to Item Group Specifications PDF document for FSA Base Specifications.

Model Upgrade/Downgrade:

Zone	Rank	Vendor	Price	Build File	Options File
Western	Primary	Tampa Truck Center	\$107,400.00	Build	Options
Northern	Primary	Tampa Truck Center	\$107,400.00	Build	Options
Central	Primary	Tampa Truck Center	\$107,400.00	Build	Options
Southern	Primary	Tampa Truck Center	\$107,400.00	Build	Options

Bid Award

Contract: FSA23-VEH21.0, Heavy Trucks and Buses

Group: Cab and Chassis Trucks: 52,000 lbs. GVWR Semi Tractor 4x6

Item: 51, Freightliner, M2, 112

Description: Refer to Item Group Specifications PDF document for FSA Base Specifications.

Model Upgrade/Downgrade:

Zone	Rank	Vendor	Price	Build File	Options File
Western	Primary	SBL Freightliner, LLC	\$107,300.00	Build	Options
	Alternate	Tampa Truck Center	\$108,611.00	Build	Options
	Alternate	Orlando Freightliner	\$110,490.00	Build	Options
Northern	Primary	SBL Freightliner, LLC	\$107,900.00	Build	Options
	Alternate	Tampa Truck Center	\$108,611.00	Build	Options
	Alternate	Orlando Freightliner	\$110,490.00	Build	Options
Central	Primary	SBL Freightliner, LLC	\$107,300.00	Build	Options
	Alternate	Tampa Truck Center	\$108,611.00	Build	Options
	Alternate	Orlando Freightliner	\$109,910.00	Build	Options
Southern	Primary	SBL Freightliner, LLC	\$105,900.00	Build	Options
	Alternate	Tampa Truck Center	\$108,611.00	Build	Options
	Alternate	Orlando Freightliner	\$110,490.00	Build	Options

Bid Award

Contract: FSA23-VEH21.0, Heavy Trucks and Buses

Group: Cab and Chassis Trucks: 52,000 lbs. GVWR Semi Tractor 4x6

Item: 52, International, HV, 613

Description: Refer to Item Group Specifications PDF document for FSA Base Specifications.

Model Upgrade/Downgrade:

Zone	Rank	Vendor	Price	Build File	Options File
Western	Primary	Cumberland International Trucks of Florida	\$115,850.00	Build	Options
Northern	Primary	Cumberland International Trucks of Florida	\$114,850.00	Build	Options
Central	Primary	Sun State International Trucks	\$114,795.00	Build	Options
	Alternate	Cumberland International Trucks of Florida	\$114,850.00	Build	Options
Southern	Primary	Rechtien International Trucks	\$115,449.00	Build	Options

Bid Award

Contract: FSA23-VEH21.0, Heavy Trucks and Buses

Group: Cab and Chassis Trucks: 52,000 lbs. GVWR Semi Tractor 4x6

Item: 53, International, HX, 62F

Description: Refer to Item Group Specifications PDF document for FSA Base Specifications.

Model Upgrade/Downgrade:

Zone	Rank	Vendor	Price	Build File	Options File
Western	Primary	Cumberland International Trucks of Florida	\$132,500.00	Build	Options
Northern	Primary	Cumberland International Trucks of Florida	\$131,500.00	Build	Options
Central	Primary	Sun State International Trucks	\$131,374.00	Build	Options
	Alternate	Cumberland International Trucks of Florida	\$131,500.00	Build	Options
Southern	Primary	Rechtien International Trucks	\$132,500.00	Build	Options

Bid Award

Contract: FSA23-VEH21.0, Heavy Trucks and Buses

Group: Cab and Chassis Trucks: 52,000 lbs. GVWR Semi Tractor 4x6

Item: 54, Kenworth, T880, T880

Description: Refer to Item Group Specifications PDF document for FSA Base Specifications.

Model Upgrade/Downgrade:

Zone	Rank	Vendor	Price	Build File	Options File
Western					
Northern	Primary	Kenworth of Jacksonville	\$142,390.00	Build	Options
Central	Primary	All Roads Kenworth, LLC.	\$142,158.00	Build	Options
	Alternate	Florida Kenworth, LLC	\$146,784.00	Build	Options
Southern	Primary	All Roads Kenworth, LLC.	\$142,158.00	Build	Options
	Alternate	Florida Kenworth, LLC	\$146,784.00	Build	Options

Bid Award

Contract: FSA23-VEH21.0, Heavy Trucks and Buses

Group: Cab and Chassis Trucks: 52,000 lbs. GVWR Semi Tractor 4x6

Item: 55, Mack, AN or G Series, AN or G Series

Description: Refer to Item Group Specifications PDF document for FSA Base Specifications.

Model Upgrade/Downgrade:

Zone	Rank	Vendor	Price	Build File	Options File
Western	Primary	Nextran Truck Centers	\$130,462.00	Build	Options
Northern	Primary	Nextran Truck Centers	\$130,462.00	Build	Options
Central	Primary	Nextran Truck Centers	\$130,462.00	Build	Options
Southern	Primary	Nextran Truck Centers	\$130,462.00	Build	Options

Bid Award

Contract: FSA23-VEH21.0, Heavy Trucks and Buses

Group: Cab and Chassis Trucks: 52,000 lbs. GVWR Semi Tractor 4x6

Item: 56, Peterbilt, 567, 567

Description: Refer to Item Group Specifications PDF document for FSA Base Specifications.

Model Upgrade/Downgrade:

Zone	Rank	Vendor	Price	Build File	Options File
Western	Primary	Rush Truck Centers of Florida, Inc.	\$161,416.00	Build	Options
Northern	Primary	Rush Truck Centers of Florida, Inc.	\$161,416.00	Build	Options
Central	Primary	Rush Truck Centers of Florida, Inc.	\$161,416.00	Build	Options
Southern	Primary	The Peterbilt Store South Florida LLC	\$163,188.00	Build	Options

Bid Award

Contract: FSA23-VEH21.0, Heavy Trucks and Buses

Group: Cab and Chassis Trucks: 52,000 lbs. GVWR Semi Tractor 4x6

Item: 57, Volvo, V Series, V Series

Description: Refer to Item Group Specifications PDF document for FSA Base Specifications.

Model Upgrade/Downgrade:

Zone	Rank	Vendor	Price	Build File	Options File
Western	Primary	Nextran Truck Centers	\$131,706.00	Build	Options
Northern	Primary	Nextran Truck Centers	\$131,706.00	Build	Options
Central	Primary	Nextran Truck Centers	\$131,706.00	Build	Options
Southern	Primary	Nextran Truck Centers	\$131,706.00	Build	Options

Bid Award

Contract: FSA23-VEH21.0, Heavy Trucks and Buses

Group: Cab and Chassis Trucks: 52,000 lbs. GVWR Semi Tractor 4x6

Item: 58, Western Star, 47X, 47X

Description: Refer to Item Group Specifications PDF document for FSA Base Specifications.

Model Upgrade/Downgrade:

Zone	Rank	Vendor	Price	Build File	Options File
Western	Primary	Tampa Truck Center	\$126,224.00	Build	Options
	Alternate	Orlando Freightliner	\$128,566.00	Build	Options
Northern	Primary	Orlando Freightliner	\$129.00	Build	Options
	Alternate	Tampa Truck Center	\$126,224.00	Build	Options
Central	Primary	Tampa Truck Center	\$126,224.00	Build	Options
	Alternate	Orlando Freightliner	\$127,986.00	Build	Options
Southern	Primary	Tampa Truck Center	\$126,244.00	Build	Options
	Alternate	Orlando Freightliner	\$128,566.00	Build	Options

Bid Award

Contract: FSA23-VEH21.0, Heavy Trucks and Buses

Group: Cab and Chassis Trucks: 52,000 lbs. GVWR Truck 4x6

Item: 59, Freightliner, M2, 112

Description: Refer to Item Group Specifications PDF document for FSA Base Specifications.

Model Upgrade/Downgrade:

Zone	Rank	Vendor	Price	Build File	Options File
Western	Primary	Orlando Freightliner	\$101,978.00	Build	Options
	Alternate	SBL Freightliner, LLC	\$102,400.00	Build	Options
	Alternate	Tampa Truck Center	\$106,903.00	Build	Options
Northern	Primary	Orlando Freightliner	\$101,978.00	Build	Options
	Alternate	SBL Freightliner, LLC	\$103,400.00	Build	Options
	Alternate	Tampa Truck Center	\$106,903.00	Build	Options
Central	Primary	Orlando Freightliner	\$101,978.00	Build	Options
	Alternate	SBL Freightliner, LLC	\$102,400.00	Build	Options
	Alternate	Tampa Truck Center	\$106,903.00	Build	Options
Southern	Primary	SBL Freightliner, LLC	\$101,200.00	Build	Options
	Alternate	Orlando Freightliner	\$101,978.00	Build	Options
	Alternate	Tampa Truck Center	\$106,903.00	Build	Options

Bid Award

Contract: FSA23-VEH21.0, Heavy Trucks and Buses

Group: Cab and Chassis Trucks: 52,000 lbs. GVWR Truck 4x6

Item: 60, International, HX, 62F

Description: Refer to Item Group Specifications PDF document for FSA Base Specifications.

Model Upgrade/Downgrade:

Zone	Rank	Vendor	Price	Build File	Options File
Western	Primary	Cumberland International Trucks of Florida	\$129,500.00	Build	Options
Northern	Primary	Cumberland International Trucks of Florida	\$128,500.00	Build	Options
Central	Primary	Sun State International Trucks	\$128,437.00	Build	Options
	Alternate	Cumberland International Trucks of Florida	\$128,500.00	Build	Options
Southern	Primary	Rechtien International Trucks	\$128,917.00	Build	Options

Bid Award

Contract: FSA23-VEH21.0, Heavy Trucks and Buses

Group: Cab and Chassis Trucks: 52,000 lbs. GVWR Truck 4x6

Item: 61, International, HV, 613

Description: Refer to Item Group Specifications PDF document for FSA Base Specifications.

Model Upgrade/Downgrade:

Zone	Rank	Vendor	Price	Build File	Options File
Western	Primary	Cumberland International Trucks of Florida	\$115,000.00	Build	Options
Northern	Primary	Cumberland International Trucks of Florida	\$114,000.00	Build	Options
Central	Primary	Sun State International Trucks	\$113,963.00	Build	Options
	Alternate	Cumberland International Trucks of Florida	\$114,000.00	Build	Options
Southern	Primary	Rechtien International Trucks	\$115,493.00	Build	Options

Bid Award

Contract: FSA23-VEH21.0, Heavy Trucks and Buses

Group: Cab and Chassis Trucks: 52,000 lbs. GVWR Truck 4x6

Item: 62, Kenworth, T880, T880

Description: Refer to Item Group Specifications PDF document for FSA Base Specifications.

Model Upgrade/Downgrade:

Zone	Rank	Vendor	Price	Build File	Options File
Western	Primary	Truckworx Kenworth	\$173,342.00	Build	Options
Northern	Primary	Kenworth of Jacksonville	\$146,040.00	Build	Options
Central	Primary	All Roads Kenworth, LLC.	\$141,729.00	Build	Options
	Alternate	Florida Kenworth, LLC	\$142,927.00	Build	Options
Southern	Primary	All Roads Kenworth, LLC.	\$141,729.00	Build	Options
	Alternate	Florida Kenworth, LLC	\$142,927.00	Build	Options

Bid Award

Contract: FSA23-VEH21.0, Heavy Trucks and Buses

Group: Cab and Chassis Trucks: 52,000 lbs. GVWR Truck 4x6

Item: 63, Mack, AN or G Series, AN or G Series

Description: Refer to Item Group Specifications PDF document for FSA Base Specifications.

Model Upgrade/Downgrade:

Zone	Rank	Vendor	Price	Build File	Options File
Western	Primary	Nextran Truck Centers	\$137,308.00	Build	Options
Northern	Primary	Nextran Truck Centers	\$137,308.00	Build	Options
Central	Primary	Nextran Truck Centers	\$137,308.00	Build	Options
Southern	Primary	Nextran Truck Centers	\$137,308.00	Build	Options

Bid Award

Contract: FSA23-VEH21.0, Heavy Trucks and Buses

Group: Cab and Chassis Trucks: 52,000 lbs. GVWR Truck 4x6

Item: 64, Peterbilt, 5671, 5671

Description: Refer to Item Group Specifications PDF document for FSA Base Specifications.

Model Upgrade/Downgrade:

Zone	Rank	Vendor	Price	Build File	Options File
Western	Primary	Rush Truck Centers of Florida, Inc.	\$161,015.00	Build	Options
Northern	Primary	Rush Truck Centers of Florida, Inc.	\$161,015.00	Build	Options
Central	Primary	Rush Truck Centers of Florida, Inc.	\$161,015.00	Build	Options
Southern	Primary	The Peterbilt Store South Florida LLC	\$165,308.00	Build	Options

Bid Award

Contract: FSA23-VEH21.0, Heavy Trucks and Buses

Group: Cab and Chassis Trucks: 52,000 lbs. GVWR Truck 4x6

Item: 65, Volvo, V Series, V Series

Description: Refer to Item Group Specifications PDF document for FSA Base Specifications.

Model Upgrade/Downgrade:

Zone	Rank	Vendor	Price	Build File	Options File
Western	Primary	Nextran Truck Centers	\$132,979.00	Build	Options
Northern	Primary	Nextran Truck Centers	\$132,979.00	Build	Options
Central	Primary	Nextran Truck Centers	\$132,979.00	Build	Options
Southern	Primary	Nextran Truck Centers	\$132,979.00	Build	Options

Bid Award

Contract: FSA23-VEH21.0, Heavy Trucks and Buses

Group: Cab and Chassis Trucks: 52,000 lbs. GVWR Truck 4x6

Item: 66, Western Star, 49X, 49X

Description: Refer to Item Group Specifications PDF document for FSA Base Specifications.

Model Upgrade/Downgrade:

Zone	Rank	Vendor	Price	Build File	Options File
Western	Primary	Orlando Freightliner	\$123,930.00	Build	Options
	Alternate	Tampa Truck Center	\$126,840.00	Build	Options
	Alternate	SBL Freightliner, LLC	\$144,599.00	Build	Options
Northern	Primary	Orlando Freightliner	\$123,930.00	Build	Options
	Alternate	Tampa Truck Center	\$126,840.00	Build	Options
	Alternate	SBL Freightliner, LLC	\$144,599.00	Build	Options
Central	Primary	Orlando Freightliner	\$123,350.00	Build	Options
	Alternate	Tampa Truck Center	\$126,840.00	Build	Options
	Alternate	SBL Freightliner, LLC	\$144,599.00	Build	Options
Southern	Primary	Orlando Freightliner	\$123,930.00	Build	Options
	Alternate	Tampa Truck Center	\$126,840.00	Build	Options
	Alternate	SBL Freightliner, LLC	\$137,599.00	Build	Options

Bid Award

Contract: FSA23-VEH21.0, Heavy Trucks and Buses

Group: Cab and Chassis: Tilt Cab (DRW) 4x2

Item: 67, Battle Motors, LNT, LNT-21

Description: Refer to Item Group Specifications PDF document for FSA Base Specifications.

Model Upgrade/Downgrade:

Zone	Rank	Vendor	Price	Build File	Options File
Western	Primary	Container Systems & Equipment Co., Inc.	\$174,741.00	Build	Options
	Alternate	All Roads Kenworth, LLC.	\$177,207.00	Build	Options
Northern	Primary	Container Systems & Equipment Co., Inc.	\$174,741.00	Build	Options
	Alternate	All Roads Kenworth, LLC.	\$177,207.00	Build	Options
Central	Primary	Container Systems & Equipment Co., Inc.	\$174,741.00	Build	Options
Southern	Primary	All Roads Kenworth, LLC.	\$177,207.00	Build	Options

Bid Award

Contract: FSA23-VEH21.0, Heavy Trucks and Buses

Group: Cab and Chassis: Tilt Cab (DRW) 4x2

Item: 68, Isuzu, NPR-HD, N3F1

Description: Refer to Item Group Specifications PDF document for FSA Base Specifications.

Model Upgrade/Downgrade:

Zone	Rank	Vendor	Price	Build File	Options File
Western	Primary	DeLand Truck Center, Inc.	\$48,136.00	Build	Options
	Alternate	TRUCKMAX ISUZU	\$49,678.00	Build	Options
	Alternate	Nextran Truck Centers	\$52,014.00	Build	Options
Northern	Primary	DeLand Truck Center, Inc.	\$48,136.00	Build	Options
	Alternate	TRUCKMAX ISUZU	\$49,678.00	Build	Options
	Alternate	Nextran Truck Centers	\$52,014.00	Build	Options
Central	Primary	DeLand Truck Center, Inc.	\$48,136.00	Build	Options
	Alternate	TRUCKMAX ISUZU	\$49,678.00	Build	Options
	Alternate	Nextran Truck Centers	\$52,014.00	Build	Options
Southern	Primary	DeLand Truck Center, Inc.	\$48,136.00	Build	Options
	Alternate	TRUCKMAX ISUZU	\$49,678.00	Build	Options
	Alternate	Nextran Truck Centers	\$52,014.00	Build	Options

Bid Award

Contract: FSA23-VEH21.0, Heavy Trucks and Buses

Group: Cab and Chassis: Tilt Cab (DRW) 4x2

Item: 69, Isuzu, FTR Chassis, MT1/G1

Description: Refer to Item Group Specifications PDF document for FSA Base Specifications.

Model Upgrade/Downgrade:

Zone	Rank	Vendor	Price	Build File	Options File
Western	Primary	DeLand Truck Center, Inc.	\$75,915.00	Build	Options
	Alternate	TRUCKMAX ISUZU	\$78,745.00	Build	Options
	Alternate	Nextran Truck Centers	\$81,075.00	Build	Options
Northern	Primary	DeLand Truck Center, Inc.	\$75,915.00	Build	Options
	Alternate	TRUCKMAX ISUZU	\$78,745.00	Build	Options
	Alternate	Nextran Truck Centers	\$81,075.00	Build	Options
Central	Primary	DeLand Truck Center, Inc.	\$75,915.00	Build	Options
	Alternate	TRUCKMAX ISUZU	\$78,745.00	Build	Options
	Alternate	Nextran Truck Centers	\$81,075.00	Build	Options
Southern	Primary	DeLand Truck Center, Inc.	\$75,915.00	Build	Options
	Alternate	TRUCKMAX ISUZU	\$78,745.00	Build	Options
	Alternate	Nextran Truck Centers	\$81,075.00	Build	Options

Bid Award

Contract: FSA23-VEH21.0, Heavy Trucks and Buses

Group: Cab and Chassis: Tilt Cab (DRW) 4x2

Item: 70, Kenworth, K270, K270

Description: Refer to Item Group Specifications PDF document for FSA Base Specifications.

Model Upgrade/Downgrade:

Zone	Rank	Vendor	Price	Build File	Options File
Western					
Northern	Primary	Kenworth of Jacksonville	\$99,510.00	Build	Options
Central	Primary	Florida Kenworth, LLC	\$96,870.00	Build	Options
	Alternate	All Roads Kenworth, LLC.	\$99,516.00	Build	Options
Southern	Primary	Florida Kenworth, LLC	\$96,870.00	Build	Options
	Alternate	All Roads Kenworth, LLC.	\$99,516.00	Build	Options

Bid Award

Contract: FSA23-VEH21.0, Heavy Trucks and Buses

Group: Cab and Chassis: Tilt Cab (DRW) 4x2

Item: 71, Peterbilt, 2201, 220

Description: Refer to Item Group Specifications PDF document for FSA Base Specifications.

Model Upgrade/Downgrade:

Zone	Rank	Vendor	Price	Build File	Options File
Western	Primary	Rush Truck Centers of Florida, Inc.	\$119,856.00	Build	Options
Northern	Primary	Rush Truck Centers of Florida, Inc.	\$119,856.00	Build	Options
Central	Primary	Rush Truck Centers of Florida, Inc.	\$119,856.00	Build	Options
Southern	Primary	The Peterbilt Store South Florida LLC	\$122,502.00	Build	Options

Bid Award

Contract: FSA23-VEH21.0, Heavy Trucks and Buses

Group: Mobile Command Unit/Critical Response Unit

Item: 76, Frontline Communications, CRU-22, CRU-22

Description: Refer to Item Group Specifications PDF document for FSA Base Specifications.

Model Upgrade/Downgrade:

Zone	Rank	Vendor	Price	Build File	Options File
Western	Primary	Ten-8 Fire & Safety, LLC	\$340,095.00	Build	Options
Northern	Primary	Ten-8 Fire & Safety, LLC	\$340,095.00	Build	Options
Central	Primary	Ten-8 Fire & Safety, LLC	\$340,095.00	Build	Options
Southern	Primary	Ten-8 Fire & Safety, LLC	\$340,095.00	Build	Options

Bid Award

Contract: FSA23-VEH21.0, Heavy Trucks and Buses

Group: Refuse Truck Electric: 60,000 lbs. GVWR 4x6 (cab and chassis only)

Item: 78, Battle Motors, LET II, LET II

Description: Refer to Item Group Specifications PDF document for FSA Base Specifications.

Model Upgrade/Downgrade:

Zone	Rank	Vendor	Price	Build File	Options File
Western	Primary	Container Systems & Equipment Co., Inc.	\$435,000.00	Build	Options
	Alternate	All Roads Kenworth, LLC.	\$466,590.00	Build	Options
	Alternate	TRUCKMAX, INC.	\$537,981.00	Build	Options
Northern	Primary	Container Systems & Equipment Co., Inc.	\$435,000.00	Build	Options
	Alternate	All Roads Kenworth, LLC.	\$463,590.00	Build	Options
	Alternate	TRUCKMAX, INC.	\$537,981.00	Build	Options
Central	Primary	Container Systems & Equipment Co., Inc.	\$435,000.00	Build	Options
	Alternate	TRUCKMAX, INC.	\$537,981.00	Build	Options
Southern	Primary	All Roads Kenworth, LLC.	\$460,590.00	Build	Options
	Alternate	TRUCKMAX, INC.	\$537,981.00	Build	Options

Bid Award

Contract: FSA23-VEH21.0, Heavy Trucks and Buses

Group: Refuse Truck Electric: 60,000 lbs. GVWR 4x6 (cab and chassis only)

Item: 80, Mack, Mack LR Electric, Mack LR Electric

Description: Refer to Item Group Specifications PDF document for FSA Base Specifications.

Model Upgrade/Downgrade:

Zone	Rank	Vendor	Price	Build File	Options File
Western	Primary	Nextran Truck Centers	\$486,414.00	Build	Options
Northern	Primary	Nextran Truck Centers	\$486,414.00	Build	Options
Central	Primary	Nextran Truck Centers	\$486,414.00	Build	Options
Southern	Primary	Nextran Truck Centers	\$486,414.00	Build	Options

Bid Award

Contract: FSA23-VEH21.0, Heavy Trucks and Buses

Group: Refuse Truck Electric: 60,000 lbs. GVWR 4x6 (cab and chassis only)

Item: 81, Peterbilt, 520EV, 520EV

Description: Refer to Item Group Specifications PDF document for FSA Base Specifications.

Model Upgrade/Downgrade:

Zone	Rank	Vendor	Price	Build File	Options File
Western	Primary	Rush Truck Centers of Florida, Inc.	\$513,746.00	Build	Options
Northern	Primary	Rush Truck Centers of Florida, Inc.	\$513,746.00	Build	Options
Central	Primary	Rush Truck Centers of Florida, Inc.	\$513,746.00	Build	Options
Southern	Primary	The Peterbilt Store South Florida LLC	\$509,545.00	Build	Options

Bid Award

Contract: FSA23-VEH21.0, Heavy Trucks and Buses

Group: Refuse Truck: 60,000 lbs. GVWR 4x6 (cab and chassis only)

Item: 82, Autocar, ACX64, ACX64

Description: Refer to Item Group Specifications PDF document for FSA Base Specifications.

Model Upgrade/Downgrade:

Zone	Rank	Vendor	Price	Build File	Options File
Western	Primary	Bachrodt FT, LLC dba Palmetto Ford of Miami	\$197,815.00	Build	Options
	Alternate	Nacarato Trucks General Partnership	\$206,413.00	Build	Options
	Alternate	Florida Kenworth, LLC	\$210,974.00	Build	Options
Northern	Primary	Bachrodt FT, LLC dba Palmetto Ford of Miami	\$196,415.00	Build	Options
	Alternate	Nacarato Trucks General Partnership	\$206,413.00	Build	Options
	Alternate	Florida Kenworth, LLC	\$210,974.00	Build	Options
Central	Primary	Bachrodt FT, LLC dba Palmetto Ford of Miami	\$194,915.00	Build	Options
	Alternate	Nacarato Trucks General Partnership	\$206,413.00	Build	Options
	Alternate	Florida Kenworth, LLC	\$209,974.00	Build	Options
Southern	Primary	Bachrodt FT, LLC dba Palmetto Ford of Miami	\$194,215.00	Build	Options
	Alternate	Nacarato Trucks General Partnership	\$206,413.00	Build	Options
	Alternate	Florida Kenworth, LLC	\$209,974.00	Build	Options

Bid Award

Contract: FSA23-VEH21.0, Heavy Trucks and Buses

Group: Refuse Truck: 60,000 lbs. GVWR 4x6 (cab and chassis only)

Item: 83, Battle Motors, LET2, LET2-44

Description: Refer to Item Group Specifications PDF document for FSA Base Specifications.

Model Upgrade/Downgrade:

Zone	Rank	Vendor	Price	Build File	Options File
Western	Primary	Container Systems & Equipment Co., Inc.	\$208,325.00	Build	Options
	Alternate	All Roads Kenworth, LLC.	\$209,939.00	Build	Options
	Alternate	TRUCKMAX, INC.	\$293,575.00	Build	Options
Northern	Primary	Container Systems & Equipment Co., Inc.	\$208,325.00	Build	Options
	Alternate	All Roads Kenworth, LLC.	\$209,939.00	Build	Options
	Alternate	TRUCKMAX, INC.	\$293,575.00	Build	Options
Central	Primary	Container Systems & Equipment Co., Inc.	\$208,325.00	Build	Options
	Alternate	TRUCKMAX, INC.	\$293,575.00	Build	Options
Southern	Primary	All Roads Kenworth, LLC.	\$209,939.00	Build	Options
	Alternate	TRUCKMAX, INC.	\$293,575.00	Build	Options

Bid Award

Contract: FSA23-VEH21.0, Heavy Trucks and Buses

Group: Refuse Truck: 60,000 lbs. GVWR 4x6 (cab and chassis only)

Item: 85, Mack, TE Series, TE Series

Description: Refer to Item Group Specifications PDF document for FSA Base Specifications.

Model Upgrade/Downgrade:

Zone	Rank	Vendor	Price	Build File	Options File
Western	Primary	Nextran Truck Centers	\$175,311.00	Build	Options
Northern	Primary	Nextran Truck Centers	\$175,311.00	Build	Options
Central	Primary	Nextran Truck Centers	\$175,311.00	Build	Options
Southern	Primary	Nextran Truck Centers	\$175,311.00	Build	Options

Bid Award

Contract: FSA23-VEH21.0, Heavy Trucks and Buses

Group: Refuse Truck: 60,000 lbs. GVWR 4x6 (cab and chassis only)

Item: 86, Peterbilt, 520, 520

Description: Refer to Item Group Specifications PDF document for FSA Base Specifications.

Model Upgrade/Downgrade:

Zone	Rank	Vendor	Price	Build File	Options File
Western	Primary	Rush Truck Centers of Florida, Inc.	\$206,815.00	Build	Options
Northern	Primary	Rush Truck Centers of Florida, Inc.	\$206,815.00	Build	Options
Central	Primary	Rush Truck Centers of Florida, Inc.	\$206,815.00	Build	Options
Southern	Primary	The Peterbilt Store South Florida LLC	\$209,896.00	Build	Options

Bid Award

Contract: FSA23-VEH21.0, Heavy Trucks and Buses

Group: Refuse Truck: Compact 9.5 Cubic Yds. Self-Loading Refuse Truck

Item: 87, Broyhill, TD3.6, TD3.6

Description: Refer to Item Group Specifications PDF document for FSA Base Specifications.

Model Upgrade/Downgrade:

Zone	Rank	Vendor	Price	Build File	Options File
Western	Primary	Broyhill Equipment LLC	\$244,183.00	Build	Options
Northern	Primary	Broyhill Equipment LLC	\$244,183.00	Build	Options
Central	Primary	Broyhill Equipment LLC	\$244,183.00	Build	Options
Southern	Primary	Broyhill Equipment LLC	\$244,183.00	Build	Options

Bid Award

Contract: FSA23-VEH21.0, Heavy Trucks and Buses

Group: Tactical Armored Vehicles

Item: 88, Terradyne, Gurkha MPV, Gurkha MPV

Description: Refer to Item Group Specifications PDF document for FSA Base Specifications.

Model Upgrade/Downgrade:

Zone	Rank	Vendor	Price	Build File	Options File
Western	Primary	Terradyne Armored Vehicles Inc.	\$217,721.00	Build	Options
Northern	Primary	Terradyne Armored Vehicles Inc.	\$217,721.00	Build	Options
Central	Primary	Terradyne Armored Vehicles Inc.	\$218,221.00	Build	Options
Southern	Primary	Terradyne Armored Vehicles Inc.	\$218,721.00	Build	Options

Bid Award

Contract: FSA23-VEH21.0, Heavy Trucks and Buses

Group: Terminal Tractor

Item: 89, Autocar, ACTT42, ACTT42

Description: Refer to Item Group Specifications PDF document for FSA Base Specifications.

Model Upgrade/Downgrade:

Zone	Rank	Vendor	Price	Build File	Options File
Western	Primary	Southern States ToyotaLift	\$142,995.00	Build	Options
	Alternate	SBL Freightliner, LLC	\$151,389.00	Build	Options
Northern	Primary	Southern States ToyotaLift	\$142,995.00	Build	Options
	Alternate	SBL Freightliner, LLC	\$151,389.00	Build	Options
Central	Primary	Southern States ToyotaLift	\$142,995.00	Build	Options
	Alternate	SBL Freightliner, LLC	\$149,389.00	Build	Options
Southern	Primary	SBL Freightliner, LLC	\$147,389.00	Build	Options

Bid Award

Contract: FSA23-VEH21.0, Heavy Trucks and Buses

Group: Terminal Tractor

Item: 90, Kalmar Ottawa, T2, 71056

Description: Refer to Item Group Specifications PDF document for FSA Base Specifications.

Model Upgrade/Downgrade:

Zone	Rank	Vendor	Price	Build File	Options File
Western	Primary	Kenworth of Jacksonville	\$139,341.00	Build	Options
	Alternate	Rechtien International Trucks	\$146,959.00	Build	Options
Northern	Primary	Kenworth of Jacksonville	\$139,240.00	Build	Options
	Alternate	Rechtien International Trucks	\$146,959.00	Build	Options
Central	Primary	Kenworth of Jacksonville	\$139,442.00	Build	Options
	Alternate	Rechtien International Trucks	\$146,959.00	Build	Options
Southern	Primary	Kenworth of Jacksonville	\$139,643.00	Build	Options
	Alternate	Rechtien International Trucks	\$146,959.00	Build	Options

Bid Award

Contract: FSA23-VEH21.0, Heavy Trucks and Buses

Group: Terminal Tractor

Item: 91, Kalmar Ottawa, T2 4x2 Offroad, 71055

Description: Refer to Item Group Specifications PDF document for FSA Base Specifications.

Model Upgrade/Downgrade:

Zone	Rank	Vendor	Price	Build File	Options File
Western	Primary	Kenworth of Jacksonville	\$135,551.00	Build	Options
	Alternate	Rechtien International Trucks	\$144,950.00	Build	Options
Northern	Primary	Kenworth of Jacksonville	\$135,450.00	Build	Options
	Alternate	Rechtien International Trucks	\$144,950.00	Build	Options
Central	Primary	Kenworth of Jacksonville	\$135,652.00	Build	Options
	Alternate	Rechtien International Trucks	\$144,950.00	Build	Options
Southern	Primary	Kenworth of Jacksonville	\$135,853.00	Build	Options
	Alternate	Rechtien International Trucks	\$144,950.00	Build	Options

Bid Award

Contract: FSA23-VEH21.0, Heavy Trucks and Buses

Group: Terminal Tractor

Item: 92, Tico, Pro-Spotter, Pro-Spotter

Description: Refer to Item Group Specifications PDF document for FSA Base Specifications.

Model Upgrade/Downgrade:

Zone	Rank	Vendor	Price	Build File	Options File
Western	Primary	Tampa Truck Center	\$141,106.00	Build	Options
	Alternate	Nacarato Trucks General Partnership	\$149,167.00	Build	Options
Northern	Primary	Tampa Truck Center	\$141,106.00	Build	Options
	Alternate	Nacarato Trucks General Partnership	\$149,167.00	Build	Options
Central	Primary	Tampa Truck Center	\$141,106.00	Build	Options
	Alternate	Nacarato Trucks General Partnership	\$149,167.00	Build	Options
Southern	Primary	Tampa Truck Center	\$141,106.00	Build	Options
	Alternate	Nacarato Trucks General Partnership	\$149,167.00	Build	Options

FSA Cooperative Purchasing Program



FSA23-VEH21.0: Heavy Trucks & Buses How to Order

How to Purchase

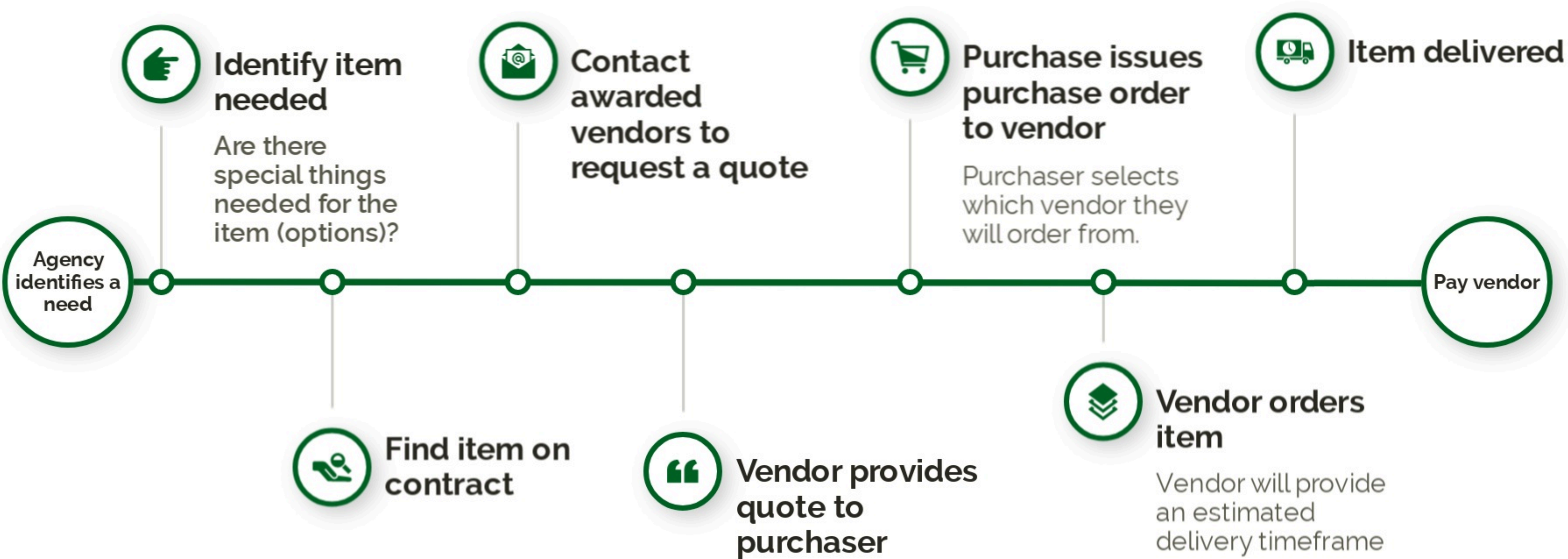

FSA Cooperative Purchasing Program



**FSA23-VEH21.0: Heavy Trucks & Buses
Awarded Vendor Contract Signature Pages**



Florida Sheriffs Association (FSA) has completed its 21st year of the cooperative purchasing heavy trucks contract. FSA is issuing the Notice of Final Award for contract FSA23-VEH21.0: Heavy Trucks & Buses that will be effective from October 1, 2023, through September 30, 2024. This year's bid included 80 items. The contract will offer class 3-5 cab & chassis trucks and buses.

The following pages are the submitted contract signature pages from the awarded vendors. The contract signature page is submitted within the Bidder Qualification Packet for the bid. By submitting a response to this Invitation to Bid and signing this form, the bidder declares that he or she has read, and the company understands, accepts and will comply with the terms, conditions and specifications of this bid and any addenda issued. The failure or omission to review this document shall in no way relieve the authorized agent of obligations with respect to this bid. The submission of a bid and signature below shall be taken as evidence of acceptance of the terms and conditions of this bid.

The bidder further declares that no other persons other than the authorized agent herein named has any interest in this bid or in the contract to be taken, and that it is made without any connection with any other person or persons making proposal for the same article and is in all respects fair and without collusion or fraud.

The bidder further declares that they have carefully examined the specifications and is thoroughly familiar with its provisions and with the quality, type and grade of materials required. The bidder further declares that they have provided a discount on all factory options included in this bid, and such discount will be included in all purchase orders.

The contract signature page may be handwritten or signed digitally. The forms that contained a digital signature have been noted as such.



CONTRACT SIGNATURE FORM

By submitting a response to this Invitation to Bid and signing this form, the Bidder declares that he or she has read, and the company understands, accepts and will comply with the terms, conditions and specifications of this bid and any addenda issued. The failure or omission to review this document shall in no way relieve the authorized agent of obligations with respect to this bid. The submission of a bid and signature below shall be taken as evidence of acceptance of the terms and conditions of this bid.

The Bidder further declares that no other persons other than the authorized agent herein named has any interest in this bid or in the contract to be taken, and that it is made without any connection with any other person or persons making proposal for the same article, and is in all respects fair and without collusion or fraud.

The Bidder further declares that they have carefully examined the specifications and is thoroughly familiar with its provisions and with the quality, type and grade of materials required.

The Bidder further declares that they have provided a discount on all factory options included in this bid, and such discount will be included in all purchase orders.

The Bidder further declares that the company understands the financial responsibility associated with this bid as stated and further declares that it has the ability to meet the financial responsibility associated with this bid.

The Bidder further declares that the company will furnish the items awarded for the price bid.

FSA Contract Number FSA23-VEH21.0: Heavy Trucks & Buses

Bidder Company Name All Roads Kenworth, LLC

Business Address 2909 S Andrews Ave
Fort Lauderdale, FL 33316

Name of Authorized Agent Michael Crawford

Email address of authorized agent

Signature *Michael Crawford*

Date 08/17/2023



CONTRACT SIGNATURE FORM

By submitting a response to this Invitation to Bid and signing this form, the Bidder declares that he or she has read, and the company understands, accepts and will comply with the terms, conditions and specifications of this bid and any addenda issued. The failure or omission to review this document shall in no way relieve the authorized agent of obligations with respect to this bid. The submission of a bid and signature below shall be taken as evidence of acceptance of the terms and conditions of this bid.

The Bidder further declares that no other persons other than the authorized agent herein named has any interest in this bid or in the contract to be taken, and that it is made without any connection with any other person or persons making proposal for the same article, and is in all respects fair and without collusion or fraud.

The Bidder further declares that they have carefully examined the specifications and is thoroughly familiar with its provisions and with the quality, type and grade of materials required.

The Bidder further declares that they have provided a discount on all factory options included in this bid, and such discount will be included in all purchase orders.

The Bidder further declares that the company understands the financial responsibility associated with this bid as stated and further declares that it has the ability to meet the financial responsibility associated with this bid.

The Bidder further declares that the company will furnish the items awarded for the price bid.

FSA Contract Number **FSA23-VEH21.0: Heavy Trucks & Buses**

Bidder Company Name **Bachrodt FT, LLC dba Palmetto Ford of Miami**

Business Address **7245 NW 36th Street, Miami, FL 33166**

Name of Authorized Agent **Charlie Rodgers**

Email address of authorized agent **crodgers@palmettofordtrucks.com**

Signature

Date **08/23/2023**



CONTRACT SIGNATURE FORM

By submitting a response to this Invitation to Bid and signing this form, the Bidder declares that he or she has read, and the company understands, accepts and will comply with the terms, conditions and specifications of this bid and any addenda issued. The failure or omission to review this document shall in no way relieve the authorized agent of obligations with respect to this bid. The submission of a bid and signature below shall be taken as evidence of acceptance of the terms and conditions of this bid.

The Bidder further declares that no other persons other than the authorized agent herein named has any interest in this bid or in the contract to be taken, and that it is made without any connection with any other person or persons making proposal for the same article, and is in all respects fair and without collusion or fraud.

The Bidder further declares that they have carefully examined the specifications and is thoroughly familiar with its provisions and with the quality, type and grade of materials required.

The Bidder further declares that they have provided a discount on all factory options included in this bid, and such discount will be included in all purchase orders.

The Bidder further declares that the company understands the financial responsibility associated with this bid as stated and further declares that it has the ability to meet the financial responsibility associated with this bid.

The Bidder further declares that the company will furnish the items awarded for the price bid.

FSA Contract Number FSA23-VEH21.0: Heavy Trucks & Buses



Bidder Company Name BOZARD FORD CO.

Business Address 540 OUTLET MALL BLVD
ST. AUGUSTINE. FL 32084

Name of Authorized Agent JEFFREY EASON

Email address of authorized agent JEASON@BOZARD.COM

Signature

Date 08/29/2023

FSA Contract Number FSA23-VEH21.0: Heavy Trucks & Buses

Bidder Company Name BOZARD FORD CO.





CONTRACT SIGNATURE FORM

By submitting a response to this Invitation to Bid and signing this form, the Bidder declares that he or she has read, and the company understands, accepts and will comply with the terms, conditions and specifications of this bid and any addenda issued. The failure or omission to review this document shall in no way relieve the authorized agent of obligations with respect to this bid. The submission of a bid and signature below shall be taken as evidence of acceptance of the terms and conditions of this bid.

The Bidder further declares that no other persons other than the authorized agent herein named has any interest in this bid or in the contract to be taken, and that it is made without any connection with any other person or persons making proposal for the same article, and is in all respects fair and without collusion or fraud.

The Bidder further declares that they have carefully examined the specifications and is thoroughly familiar with its provisions and with the quality, type and grade of materials required.

The Bidder further declares that they have provided a discount on all factory options included in this bid, and such discount will be included in all purchase orders.

The Bidder further declares that the company understands the financial responsibility associated with this bid as stated and further declares that it has the ability to meet the financial responsibility associated with this bid.

The Bidder further declares that the company will furnish the items awarded for the price bid.

FSA Contract Number FSA23-VEH21.0: Heavy Trucks & Buses

Bidder Company Name Broyhill Equipment LLC

Business Address One North Market Square PO Box 475 Dakota City NE 68731-0475

Name of Authorized Agent Tammy Steemken

Email address of authorized agent tammy.steemken@broyhill.com

Signature

Date 08/21/2023

FSA Contract Number FSA23-VEH21.0: Heavy Trucks & Buses

Bidder Company Name
Broyhill Equipment LLC



CONTRACT SIGNATURE FORM

By submitting a response to this Invitation to Bid and signing this form, the Bidder declares that he or she has read, and the company understands, accepts and will comply with the terms, conditions and specifications of this bid and any addenda issued. The failure or omission to review this document shall in no way relieve the authorized agent of obligations with respect to this bid. The submission of a bid and signature below shall be taken as evidence of acceptance of the terms and conditions of this bid.

The Bidder further declares that no other persons other than the authorized agent herein named has any interest in this bid or in the contract to be taken, and that it is made without any connection with any other person or persons making proposal for the same article, and is in all respects fair and without collusion or fraud.

The Bidder further declares that they have carefully examined the specifications and is thoroughly familiar with its provisions and with the quality, type and grade of materials required.

The Bidder further declares that they have provided a discount on all factory options included in this bid, and such discount will be included in all purchase orders.

The Bidder further declares that the company understands the financial responsibility associated with this bid as stated and further declares that it has the ability to meet the financial responsibility associated with this bid.

The Bidder further declares that the company will furnish the items awarded for the price bid.

FSA Contract Number **FSA23-VEH21.0: Heavy Trucks & Buses**

Bidder Company Name **Container Systems & Equipment Co., Inc.**

Business Address **506 Bellevue Av., Daytona Beach, FL 32114**

Name of Authorized Agent **William Young**

Email address of authorized agent **wguinnyoung@gmail.com**

Signature

A handwritten signature in blue ink that reads "William Young". The signature is fluid and cursive, with a large loop at the end.

Date **August 25, 2023**

FSA Contract Number **FSA23-VEH21.0: Heavy Trucks & Buses**

Bidder Company Name **Container Systems & Equipment Co., Inc.**



CONTRACT SIGNATURE FORM

By submitting a response to this Invitation to Bid and signing this form, the Bidder declares that he or she has read, and the company understands, accepts and will comply with the terms, conditions and specifications of this bid and any addenda issued. The failure or omission to review this document shall in no way relieve the authorized agent of obligations with respect to this bid. The submission of a bid and signature below shall be taken as evidence of acceptance of the terms and conditions of this bid.

The Bidder further declares that no other persons other than the authorized agent herein named has any interest in this bid or in the contract to be taken, and that it is made without any connection with any other person or persons making proposal for the same article, and is in all respects fair and without collusion or fraud.

The Bidder further declares that they have carefully examined the specifications and is thoroughly familiar with its provisions and with the quality, type and grade of materials required.

The Bidder further declares that they have provided a discount on all factory options included in this bid, and such discount will be included in all purchase orders.

The Bidder further declares that the company understands the financial responsibility associated with this bid as stated and further declares that it has the ability to meet the financial responsibility associated with this bid.

The Bidder further declares that the company will furnish the items awarded for the price bid.

FSA Contract Number FSA23-VEH21.0: Heavy Trucks & Buses

Bidder Company Name Model 1 Commercial Vehicles, Inc.

Business Address 8600 Atlantic Boulevard
Tallahassee, Florida

Name of Authorized Agent Nick Corley

Email address of authorized agent BidDepartment@Model1.com

Signature

Date 08/29/2023



CONTRACT SIGNATURE FORM

By submitting a response to this Invitation to Bid and signing this form, the Bidder declares that he or she has read, and the company understands, accepts and will comply with the terms, conditions and specifications of this bid and any addenda issued. The failure or omission to review this document shall in no way relieve the authorized agent of obligations with respect to this bid. The submission of a bid and signature below shall be taken as evidence of acceptance of the terms and conditions of this bid.

The Bidder further declares that no other persons other than the authorized agent herein named has any interest in this bid or in the contract to be taken, and that it is made without any connection with any other person or persons making proposal for the same article, and is in all respects fair and without collusion or fraud.

The Bidder further declares that they have carefully examined the specifications and is thoroughly familiar with its provisions and with the quality, type and grade of materials required.

The Bidder further declares that they have provided a discount on all factory options included in this bid, and such discount will be included in all purchase orders.

The Bidder further declares that the company understands the financial responsibility associated with this bid as stated and further declares that it has the ability to meet the financial responsibility associated with this bid.

The Bidder further declares that the company will furnish the items awarded for the price bid.

FSA Contract Number FSA23-VEH21.0: Heavy Trucks & Buses



Bidder Company Name Cumberland International Trucks of Florida, LLC

Business Address 2110 S. Division Ave
Orlando, FL 32805



Name of Authorized Agent Chuck Calhoun

Email address of authorized agent ccalhoun@cltte.com

Signature

Date 9-21-23

FSA Contract Number FSA23-VEH21.0: Heavy Trucks & Buses

Bidder Company Name Cumberland International Trucks of Florida, LLC





CONTRACT SIGNATURE FORM

By submitting a response to this Invitation to Bid and signing this form, the Bidder declares that he or she has read, and the company understands, accepts and will comply with the terms, conditions and specifications of this bid and any addenda issued. The failure or omission to review this document shall in no way relieve the authorized agent of obligations with respect to this bid. The submission of a bid and signature below shall be taken as evidence of acceptance of the terms and conditions of this bid.

The Bidder further declares that no other persons other than the authorized agent herein named has any interest in this bid or in the contract to be taken, and that it is made without any connection with any other person or persons making proposal for the same article, and is in all respects fair and without collusion or fraud.

The Bidder further declares that they have carefully examined the specifications and is thoroughly familiar with its provisions and with the quality, type and grade of materials required.

The Bidder further declares that they have provided a discount on all factory options included in this bid, and such discount will be included in all purchase orders.

The Bidder further declares that the company understands the financial responsibility associated with this bid as stated and further declares that it has the ability to meet the financial responsibility associated with this bid.

The Bidder further declares that the company will furnish the items awarded for the price bid.

FSA Contract Number FSA23-VEH21.0: Heavy Trucks & Buses

Bidder Company Name Deland Truck Center, inc.

Business Address 1208 South Woodland Blvd.
Deland Florida 32720

Name of Authorized Agent Howard B. Williams

Email address of authorized agent howard@delandtruckcenter.com

Signature *Howard B. Williams*

Date 8/18/2023

FSA Contract Number FSA23-VEH21.0: Heavy Trucks & Buses
Bidder Company Name
Deland Truck Center, inc.



CONTRACT SIGNATURE FORM

By submitting a response to this Invitation to Bid and signing this form, the Bidder declares that he or she has read, and the company understands, accepts and will comply with the terms, conditions and specifications of this bid and any addenda issued. The failure or omission to review this document shall in no way relieve the authorized agent of obligations with respect to this bid. The submission of a bid and signature below shall be taken as evidence of acceptance of the terms and conditions of this bid.

The Bidder further declares that no other persons other than the authorized agent herein named has any interest in this bid or in the contract to be taken, and that it is made without any connection with any other person or persons making proposal for the same article, and is in all respects fair and without collusion or fraud.

The Bidder further declares that they have carefully examined the specifications and is thoroughly familiar with its provisions and with the quality, type and grade of materials required.

The Bidder further declares that they have provided a discount on all factory options included in this bid, and such discount will be included in all purchase orders.

The Bidder further declares that the company understands the financial responsibility associated with this bid as stated and further declares that it has the ability to meet the financial responsibility associated with this bid.

The Bidder further declares that the company will furnish the items awarded for the price bid.

FSA Contract Number FSA23-VEH21.0: Heavy Trucks & Buses

Bidder Company Name DUVAL FORD LLC

Business Address 1616 CASSAT AVE; JACKSONVILLE FL32210

Name of Authorized Agent RICHARD TACKETT

Email address of authorized agent RICHARD.TACKETT@DUVALFORD.COM

Signature

Date 8/20/23

FSA Contract Number FSA23-VEH21.0: Heavy Trucks & Buses

Bidder Company Name
DUVAL FORD LLC



CONTRACT SIGNATURE FORM

By submitting a response to this Invitation to Bid and signing this form, the Bidder declares that he or she has read, and the company understands, accepts and will comply with the terms, conditions and specifications of this bid and any addenda issued. The failure or omission to review this document shall in no way relieve the authorized agent of obligations with respect to this bid. The submission of a bid and signature below shall be taken as evidence of acceptance of the terms and conditions of this bid.

The Bidder further declares that no other persons other than the authorized agent herein named has any interest in this bid or in the contract to be taken, and that it is made without any connection with any other person or persons making proposal for the same article, and is in all respects fair and without collusion or fraud.

The Bidder further declares that they have carefully examined the specifications and is thoroughly familiar with its provisions and with the quality, type and grade of materials required.

The Bidder further declares that they have provided a discount on all factory options included in this bid, and such discount will be included in all purchase orders.

The Bidder further declares that the company understands the financial responsibility associated with this bid as stated and further declares that it has the ability to meet the financial responsibility associated with this bid.

The Bidder further declares that the company will furnish the items awarded for the price bid.

FSA Contract Number FSA23-VEH21.0: Heavy Trucks & Buses

Bidder Company Name Florida Kenworth, LLC.

Business Address 1800 North Orange Blossom Trail
Orlando, FL 32804

Name of Authorized Agent Matthew Peterson

Email address of authorized agent matt.peterson@csctruck.com

Signature 

Date 08/16/2023

FSA Contract Number FSA23-VEH21.0: Heavy Trucks & Buses
Bidder Company Name Florida Kenworth, LLC.





CONTRACT SIGNATURE FORM

By submitting a response to this Invitation to Bid and signing this form, the Bidder declares that he or she has read, and the company understands, accepts and will comply with the terms, conditions and specifications of this bid and any addenda issued. The failure or omission to review this document shall in no way relieve the authorized agent of obligations with respect to this bid. The submission of a bid and signature below shall be taken as evidence of acceptance of the terms and conditions of this bid.

The Bidder further declares that no other persons other than the authorized agent herein named has any interest in this bid or in the contract to be taken, and that it is made without any connection with any other person or persons making proposal for the same article, and is in all respects fair and without collusion or fraud.

The Bidder further declares that they have carefully examined the specifications and is thoroughly familiar with its provisions and with the quality, type and grade of materials required.

The Bidder further declares that they have provided a discount on all factory options included in this bid, and such discount will be included in all purchase orders.

The Bidder further declares that the company understands the financial responsibility associated with this bid as stated and further declares that it has the ability to meet the financial responsibility associated with this bid.

The Bidder further declares that the company will furnish the items awarded for the price bid.

FSA Contract Number FSA23-VEH21.0: Heavy Trucks & Buses

Bidder Company Name Florida Transportation Systems, Inc.

Business Address 6041 Orient Road Tampa, Florida 33610

Name of Authorized Agent Robert Frick

Email address of authorized agent rfrick@fts4buses.com

Signature

Date 08/09/2023



CONTRACT SIGNATURE FORM

By submitting a response to this Invitation to Bid and signing this form, the Bidder declares that he or she has read, and the company understands, accepts and will comply with the terms, conditions and specifications of this bid and any addenda issued. The failure or omission to review this document shall in no way relieve the authorized agent of obligations with respect to this bid. The submission of a bid and signature below shall be taken as evidence of acceptance of the terms and conditions of this bid.

The Bidder further declares that no other persons other than the authorized agent herein named has any interest in this bid or in the contract to be taken, and that it is made without any connection with any other person or persons making proposal for the same article, and is in all respects fair and without collusion or fraud.

The Bidder further declares that they have carefully examined the specifications and is thoroughly familiar with its provisions and with the quality, type and grade of materials required.

The Bidder further declares that they have provided a discount on all factory options included in this bid, and such discount will be included in all purchase orders.

The Bidder further declares that the company understands the financial responsibility associated with this bid as stated and further declares that it has the ability to meet the financial responsibility associated with this bid.

The Bidder further declares that the company will furnish the items awarded for the price bid.

FSA Contract Number FSA23-VEH21.0: Heavy Trucks & Buses



Bidder Company Name KENWORTH OF JACKSONVILLE

Business Address 1121 SUEMAC ROAD
JACKSONVILLE, FL 32254

Name of Authorized Agent ED COSTELLO

Email address of authorized agent edcostello@kwjax.com

Signature

Date 08/28/2023



CONTRACT SIGNATURE FORM

By submitting a response to this Invitation to Bid and signing this form, the Bidder declares that he or she has read, and the company understands, accepts and will comply with the terms, conditions and specifications of this bid and any addenda issued. The failure or omission to review this document shall in no way relieve the authorized agent of obligations with respect to this bid. The submission of a bid and signature below shall be taken as evidence of acceptance of the terms and conditions of this bid.

The Bidder further declares that no other persons other than the authorized agent herein named has any interest in this bid or in the contract to be taken, and that it is made without any connection with any other person or persons making proposal for the same article, and is in all respects fair and without collusion or fraud.

The Bidder further declares that they have carefully examined the specifications and is thoroughly familiar with its provisions and with the quality, type and grade of materials required.

The Bidder further declares that they have provided a discount on all factory options included in this bid, and such discount will be included in all purchase orders.

The Bidder further declares that the company understands the financial responsibility associated with this bid as stated and further declares that it has the ability to meet the financial responsibility associated with this bid.

The Bidder further declares that the company will furnish the items awarded for the price bid.

FSA Contract Number FSA23-VEH21.0: Heavy Trucks & Buses

Bidder Company Name Matthews Bus Alliance Inc.

Business Address 4802 West Colonial Dr, Orlando, FL 32808

Name of Authorized Agent Glenn J Matthews

Email address of authorized agent gmatthews@matthewsbusesflorida.com

Signature 
Date 8-24-2023





CONTRACT SIGNATURE FORM

By submitting a response to this Invitation to Bid and signing this form, the Bidder declares that he or she has read, and the company understands, accepts and will comply with the terms, conditions and specifications of this bid and any addenda issued. The failure or omission to review this document shall in no way relieve the authorized agent of obligations with respect to this bid. The submission of a bid and signature below shall be taken as evidence of acceptance of the terms and conditions of this bid.

The Bidder further declares that no other persons other than the authorized agent herein named has any interest in this bid or in the contract to be taken, and that it is made without any connection with any other person or persons making proposal for the same article, and is in all respects fair and without collusion or fraud.

The Bidder further declares that they have carefully examined the specifications and is thoroughly familiar with its provisions and with the quality, type and grade of materials required.

The Bidder further declares that they have provided a discount on all factory options included in this bid, and such discount will be included in all purchase orders.

The Bidder further declares that the company understands the financial responsibility associated with this bid as stated and further declares that it has the ability to meet the financial responsibility associated with this bid.

The Bidder further declares that the company will furnish the items awarded for the price bid.

FSA Contract Number FSA23-VEH21.0: Heavy Trucks & Buses

Bidder Company Name Nacarato Truck Centers

Business Address 360 S Military Trl
West Palm Beach, FL 33415

Name of Authorized Agent Pat Daily COO

Email address of authorized agent pat.daily@nacarato.com

Signature *Pat Daily*

Date 8/17/23

FSA Contract Number FSA23-VEH21.0: Heavy Trucks & Buses
Bidder Company Name Nacarato Truck Centers





CONTRACT SIGNATURE FORM

By submitting a response to this Invitation to Bid and signing this form, the Bidder declares that he or she has read, and the company understands, accepts and will comply with the terms, conditions and specifications of this bid and any addenda issued. The failure or omission to review this document shall in no way relieve the authorized agent of obligations with respect to this bid. The submission of a bid and signature below shall be taken as evidence of acceptance of the terms and conditions of this bid.

The Bidder further declares that no other persons other than the authorized agent herein named has any interest in this bid or in the contract to be taken, and that it is made without any connection with any other person or persons making proposal for the same article, and is in all respects fair and without collusion or fraud.

The Bidder further declares that they have carefully examined the specifications and is thoroughly familiar with its provisions and with the quality, type and grade of materials required.

The Bidder further declares that they have provided a discount on all factory options included in this bid, and such discount will be included in all purchase orders.

The Bidder further declares that the company understands the financial responsibility associated with this bid as stated and further declares that it has the ability to meet the financial responsibility associated with this bid.

The Bidder further declares that the company will furnish the items awarded for the price bid.

FSA Contract Number FSA23-VEH21.0: Heavy Trucks & Buses

Bidder Company Name Nextran Truck Centers

Business Address 1986 West Beaver Street. Jacksonville, FL 32209

Name of Authorized Agent Anthony Abatecola

Email address of authorized agent Aabatecola@nextranusa.com

Signature

Date 08/22/2023



CONTRACT SIGNATURE FORM

By submitting a response to this Invitation to Bid and signing this form, the Bidder declares that he or she has read, and the company understands, accepts and will comply with the terms, conditions and specifications of this bid and any addenda issued. The failure or omission to review this document shall in no way relieve the authorized agent of obligations with respect to this bid. The submission of a bid and signature below shall be taken as evidence of acceptance of the terms and conditions of this bid.

The Bidder further declares that no other persons other than the authorized agent herein named has any interest in this bid or in the contract to be taken, and that it is made without any connection with any other person or persons making proposal for the same article, and is in all respects fair and without collusion or fraud.

The Bidder further declares that they have carefully examined the specifications and is thoroughly familiar with its provisions and with the quality, type and grade of materials required.

The Bidder further declares that they have provided a discount on all factory options included in this bid, and such discount will be included in all purchase orders.

The Bidder further declares that the company understands the financial responsibility associated with this bid as stated and further declares that it has the ability to meet the financial responsibility associated with this bid.

The Bidder further declares that the company will furnish the items awarded for the price bid.

FSA Contract Number FSA23-VEH21.0: Heavy Trucks & Buses

Bidder Company Name Phoenix Motorcars Leasing LLC DBA Phoenix Electric Sales

Business Address 1500 Lakeview Loop
Phoenix, AZ 85007

Name of Authorized Agent Jose Paul

Email address of authorized agent josep@phoenixmotorcars.com

Signature

Date 08/30/2023



CONTRACT SIGNATURE FORM

By submitting a response to this Invitation to Bid and signing this form, the Bidder declares that he or she has read, and the company understands, accepts and will comply with the terms, conditions and specifications of this bid and any addenda issued. The failure or omission to review this document shall in no way relieve the authorized agent of obligations with respect to this bid. The submission of a bid and signature below shall be taken as evidence of acceptance of the terms and conditions of this bid.

The Bidder further declares that no other persons other than the authorized agent herein named has any interest in this bid or in the contract to be taken, and that it is made without any connection with any other person or persons making proposal for the same article, and is in all respects fair and without collusion or fraud.

The Bidder further declares that they have carefully examined the specifications and is thoroughly familiar with its provisions and with the quality, type and grade of materials required.

The Bidder further declares that they have provided a discount on all factory options included in this bid, and such discount will be included in all purchase orders.

The Bidder further declares that the company understands the financial responsibility associated with this bid as stated and further declares that it has the ability to meet the financial responsibility associated with this bid.

The Bidder further declares that the company will furnish the items awarded for the price bid.

FSA Contract Number FSA23-VEH21.0: Heavy Trucks & Buses

Bidder Company Name Orlando Freightliner

Business Address 2455 South Orange Blossom Trail Apopka Fl. 32703

Name of Authorized Agent Bob Scharpnick

Email address of authorized agent bscharpnick@orlandofreightliner.com

Signature

Date 08/07/2023





CONTRACT SIGNATURE FORM

By submitting a response to this Invitation to Bid and signing this form, the Bidder declares that he or she has read, and the company understands, accepts and will comply with the terms, conditions and specifications of this bid and any addenda issued. The failure or omission to review this document shall in no way relieve the authorized agent of obligations with respect to this bid. The submission of a bid and signature below shall be taken as evidence of acceptance of the terms and conditions of this bid.

The Bidder further declares that no other persons other than the authorized agent herein named has any interest in this bid or in the contract to be taken, and that it is made without any connection with any other person or persons making proposal for the same article, and is in all respects fair and without collusion or fraud.

The Bidder further declares that they have carefully examined the specifications and is thoroughly familiar with its provisions and with the quality, type and grade of materials required.

The Bidder further declares that they have provided a discount on all factory options included in this bid, and such discount will be included in all purchase orders.

The Bidder further declares that the company understands the financial responsibility associated with this bid as stated and further declares that it has the ability to meet the financial responsibility associated with this bid.

The Bidder further declares that the company will furnish the items awarded for the price bid.

FSA Contract Number FSA23-VEH21.0: Heavy Trucks & Buses

Bidder Company Name The Peterbilt Store South Florida

Business Address 2441 S State Rd. 7 Ft. Lauderdale, Fl. 33317

Name of Authorized Agent Andy Hallums

Email address of authorized agent ahallums@thepetestore.com

Signature

Date 08/28/2023



CONTRACT SIGNATURE FORM

By submitting a response to this Invitation to Bid and signing this form, the Bidder declares that he or she has read, and the company understands, accepts and will comply with the terms, conditions and specifications of this bid and any addenda issued. The failure or omission to review this document shall in no way relieve the authorized agent of obligations with respect to this bid. The submission of a bid and signature below shall be taken as evidence of acceptance of the terms and conditions of this bid.

The Bidder further declares that no other persons other than the authorized agent herein named has any interest in this bid or in the contract to be taken, and that it is made without any connection with any other person or persons making proposal for the same article, and is in all respects fair and without collusion or fraud.

The Bidder further declares that they have carefully examined the specifications and is thoroughly familiar with its provisions and with the quality, type and grade of materials required.

The Bidder further declares that they have provided a discount on all factory options included in this bid, and such discount will be included in all purchase orders.

The Bidder further declares that the company understands the financial responsibility associated with this bid as stated and further declares that it has the ability to meet the financial responsibility associated with this bid.

The Bidder further declares that the company will furnish the items awarded for the price bid.

FSA Contract Number FSA23-VEH21.0: Heavy Trucks & Buses

Bidder Company Name RECHTIEN INTERNATIONAL TRUCKS, INC

Business Address 7227 NW 74th Avenue, Miami, FL 33166

Name of Authorized Agent Carlos Currin

Email address of authorized agent ccurrin@rechtien.com

Signature

Date 07/31/2023

FSA Contract Number FSA23-VEH21.0: Heavy Trucks & Buses

Bidder Company Name RECHTIEN INTERNATIONAL TRUCKS, INC



CONTRACT SIGNATURE FORM

By submitting a response to this Invitation to Bid and signing this form, the Bidder declares that he or she has read, and the company understands, accepts and will comply with the terms, conditions and specifications of this bid and any addenda issued. The failure or omission to review this document shall in no way relieve the authorized agent of obligations with respect to this bid. The submission of a bid and signature below shall be taken as evidence of acceptance of the terms and conditions of this bid.

The Bidder further declares that no other persons other than the authorized agent herein named has any interest in this bid or in the contract to be taken, and that it is made without any connection with any other person or persons making proposal for the same article, and is in all respects fair and without collusion or fraud.

The Bidder further declares that they have carefully examined the specifications and is thoroughly familiar with its provisions and with the quality, type and grade of materials required.

The Bidder further declares that they have provided a discount on all factory options included in this bid, and such discount will be included in all purchase orders.

The Bidder further declares that the company understands the financial responsibility associated with this bid as stated and further declares that it has the ability to meet the financial responsibility associated with this bid.

The Bidder further declares that the company will furnish the items awarded for the price bid.

FSA Contract Number FSA23-VEH21.0: Heavy Trucks & Buses

Bidder Company Name Rush Truck Centers of Florida, Inc.

Business Address 8111 East Adamo Dr., Tampa, FL 33619

Name of Authorized Agent Wade Bosarge

Email address of authorized agent canadinep@rushenterprises.com

Signature

Date 09/06/2023



CONTRACT SIGNATURE FORM

By submitting a response to this Invitation to Bid and signing this form, the Bidder declares that he or she has read, and the company understands, accepts and will comply with the terms, conditions and specifications of this bid and any addenda issued. The failure or omission to review this document shall in no way relieve the authorized agent of obligations with respect to this bid. The submission of a bid and signature below shall be taken as evidence of acceptance of the terms and conditions of this bid.

The Bidder further declares that no other persons other than the authorized agent herein named has any interest in this bid or in the contract to be taken, and that it is made without any connection with any other person or persons making proposal for the same article, and is in all respects fair and without collusion or fraud.

The Bidder further declares that they have carefully examined the specifications and is thoroughly familiar with its provisions and with the quality, type and grade of materials required.

The Bidder further declares that they have provided a discount on all factory options included in this bid, and such discount will be included in all purchase orders.

The Bidder further declares that the company understands the financial responsibility associated with this bid as stated and further declares that it has the ability to meet the financial responsibility associated with this bid.

The Bidder further declares that the company will furnish the items awarded for the price bid.

FSA Contract Number FSA23-VEH21.0: Heavy Trucks & Buses

Bidder Company Name SBL FREIGHTLINER, LLC

Business Address 2840 CENTER PORT CIRCLE POMPNAO BEACH FL 33064

Name of Authorized Agent DONALD MAHER

Email address of authorized agent DMAHER@FREIGHTLINERFL.COM

Signature

Date 08/07/2023





CONTRACT SIGNATURE FORM

By submitting a response to this Invitation to Bid and signing this form, the Bidder declares that he or she has read, and the company understands, accepts and will comply with the terms, conditions and specifications of this bid and any addenda issued. The failure or omission to review this document shall in no way relieve the authorized agent of obligations with respect to this bid. The submission of a bid and signature below shall be taken as evidence of acceptance of the terms and conditions of this bid.

The Bidder further declares that no other persons other than the authorized agent herein named has any interest in this bid or in the contract to be taken, and that it is made without any connection with any other person or persons making proposal for the same article, and is in all respects fair and without collusion or fraud.

The Bidder further declares that they have carefully examined the specifications and is thoroughly familiar with its provisions and with the quality, type and grade of materials required.

The Bidder further declares that they have provided a discount on all factory options included in this bid, and such discount will be included in all purchase orders.

The Bidder further declares that the company understands the financial responsibility associated with this bid as stated and further declares that it has the ability to meet the financial responsibility associated with this bid.

The Bidder further declares that the company will furnish the items awarded for the price bid.

FSA Contract Number FSA23-VEH21.0: Heavy Trucks & Buses

Bidder Company Name Southern States ToyotaLift

Business Address 115 South 78th Street
Tampa FL 33619

Name of Authorized Agent Shane Polson

Email address of authorized agent spolson@sstlift.com

Signature

Date 08/23/2023





CONTRACT SIGNATURE FORM

By submitting a response to this Invitation to Bid and signing this form, the Bidder declares that he or she has read, and the company understands, accepts and will comply with the terms, conditions and specifications of this bid and any addenda issued. The failure or omission to review this document shall in no way relieve the authorized agent of obligations with respect to this bid. The submission of a bid and signature below shall be taken as evidence of acceptance of the terms and conditions of this bid.

The Bidder further declares that no other persons other than the authorized agent herein named has any interest in this bid or in the contract to be taken, and that it is made without any connection with any other person or persons making proposal for the same article, and is in all respects fair and without collusion or fraud.

The Bidder further declares that they have carefully examined the specifications and is thoroughly familiar with its provisions and with the quality, type and grade of materials required.

The Bidder further declares that they have provided a discount on all factory options included in this bid, and such discount will be included in all purchase orders.

The Bidder further declares that the company understands the financial responsibility associated with this bid as stated and further declares that it has the ability to meet the financial responsibility associated with this bid.

The Bidder further declares that the company will furnish the items awarded for the price bid.

FSA Contract Number FSA23-VEH21.0: Heavy Trucks & Buses

Bidder Company Name Sun State International Tucks, LLC

Business Address 6020 Adamo Drive

Name of Authorized Agent David Metcalf

Email address of authorized agent dave.metcalf@sunstateintl.com

Signature *David Metcalf*

Date 08/14/2023





CONTRACT SIGNATURE FORM

By submitting a response to this Invitation to Bid and signing this form, the Bidder declares that he or she has read, and the company understands, accepts and will comply with the terms, conditions and specifications of this bid and any addenda issued. The failure or omission to review this document shall in no way relieve the authorized agent of obligations with respect to this bid. The submission of a bid and signature below shall be taken as evidence of acceptance of the terms and conditions of this bid.

The Bidder further declares that no other persons other than the authorized agent herein named has any interest in this bid or in the contract to be taken, and that it is made without any connection with any other person or persons making proposal for the same article, and is in all respects fair and without collusion or fraud.

The Bidder further declares that they have carefully examined the specifications and is thoroughly familiar with its provisions and with the quality, type and grade of materials required.

The Bidder further declares that they have provided a discount on all factory options included in this bid, and such discount will be included in all purchase orders.

The Bidder further declares that the company understands the financial responsibility associated with this bid as stated and further declares that it has the ability to meet the financial responsibility associated with this bid.

The Bidder further declares that the company will furnish the items awarded for the price bid.

FSA Contract Number FSA23-VEH21.0: Heavy Trucks & Buses

Bidder Company Name Tampa Truck Center LLC

Business Address 7528 US HWY 301 N
Tampa, FL 33637

Name of Authorized Agent Scott Endris

Email address of authorized agent sendris@southporttruck.com

Signature 

Date 08/07/2023





CONTRACT SIGNATURE FORM

By submitting a response to this Invitation to Bid and signing this form, the Bidder declares that he or she has read, and the company understands, accepts and will comply with the terms, conditions and specifications of this bid and any addenda issued. The failure or omission to review this document shall in no way relieve the authorized agent of obligations with respect to this bid. The submission of a bid and signature below shall be taken as evidence of acceptance of the terms and conditions of this bid.

The Bidder further declares that no other persons other than the authorized agent herein named has any interest in this bid or in the contract to be taken, and that it is made without any connection with any other person or persons making proposal for the same article, and is in all respects fair and without collusion or fraud.

The Bidder further declares that they have carefully examined the specifications and is thoroughly familiar with its provisions and with the quality, type and grade of materials required.

The Bidder further declares that they have provided a discount on all factory options included in this bid, and such discount will be included in all purchase orders.

The Bidder further declares that the company understands the financial responsibility associated with this bid as stated and further declares that it has the ability to meet the financial responsibility associated with this bid.

The Bidder further declares that the company will furnish the items awarded for the price bid.

FSA Contract Number FSA23-VEH21.0: Heavy Trucks & Buses

Bidder Company Name Ten-8 Fire & Safety, LLC

Business Address 2950 59th Ave. Dr. E. Bradenton, FL 34203

Name of Authorized Agent Blake Ebben

Email address of authorized agent bebben@ten8fire.com

Signature

Date 08/07/2023



CONTRACT SIGNATURE FORM

By submitting a response to this Invitation to Bid and signing this form, the Bidder declares that he or she has read, and the company understands, accepts and will comply with the terms, conditions and specifications of this bid and any addenda issued. The failure or omission to review this document shall in no way relieve the authorized agent of obligations with respect to this bid. The submission of a bid and signature below shall be taken as evidence of acceptance of the terms and conditions of this bid.

The Bidder further declares that no other persons other than the authorized agent herein named has any interest in this bid or in the contract to be taken, and that it is made without any connection with any other person or persons making proposal for the same article, and is in all respects fair and without collusion or fraud.

The Bidder further declares that they have carefully examined the specifications and is thoroughly familiar with its provisions and with the quality, type and grade of materials required.

The Bidder further declares that they have provided a discount on all factory options included in this bid, and such discount will be included in all purchase orders.

The Bidder further declares that the company understands the financial responsibility associated with this bid as stated and further declares that it has the ability to meet the financial responsibility associated with this bid.

The Bidder further declares that the company will furnish the items awarded for the price bid.

FSA Contract Number FSA23-VEH21.0: Heavy Trucks & Buses

Bidder Company Name [Terradyne Armored Vehicles Inc.](#)

Business Address [1-402 Mulock Drive, Newmarket, Ontario L3Y 9B8](#)

Name of Authorized Agent [Lucus Witzke](#)

Email address of authorized agent lucus.witzke@terradyneinc.com

Signature

Date 08/30/2023



CONTRACT SIGNATURE FORM

By submitting a response to this Invitation to Bid and signing this form, the bidder declares that he or she has read, and the company understands, accepts and will comply with the terms, conditions and specifications of this bid and any addenda issued. The failure or omission to review this document shall in no way relieve the authorized agent of obligations with respect to this bid. The submission of a bid and signature below shall be taken as evidence of acceptance of the terms and conditions of this bid.

The bidder further declares that no other persons other than the authorized agent herein named has any interest in this bid or in the contract to be taken, and that it is made without any connection with any other person or persons making proposal for the same article, and is in all respects fair and without collusion or fraud.

The bidder further declares that they have carefully examined the specifications and is thoroughly familiar with its provisions and with the quality, type and grade of materials required.

The bidder further declares that they have provided a discount on all factory options included in this bid, and such discount will be included in all purchase orders.

The bidder further declares that the company understands the financial responsibility associated with this bid as stated and further declares that it has the ability to meet the financial responsibility associated with this bid.

The bidder further declares that the company will furnish the items awarded for the price bid.

FSA Contract Number FSA22-VEL30.0

Bidder Company Name TRUCKMAX ISUZU

Business Address 29020 South Dixie Hwy, Homestead, FL, 33033

Name of Authorized Agent GUILLERMO CHEZ

Email address of authorized agent MYTRUCKS101@GMAIL.COM

Signature

Date 08/04/2023



CONTRACT SIGNATURE FORM

By submitting a response to this Invitation to Bid and signing this form, the bidder declares that he or she has read, and the company understands, accepts and will comply with the terms, conditions and specifications of this bid and any addenda issued. The failure or omission to review this document shall in no way relieve the authorized agent of obligations with respect to this bid. The submission of a bid and signature below shall be taken as evidence of acceptance of the terms and conditions of this bid.

The bidder further declares that no other persons other than the authorized agent herein named has any interest in this bid or in the contract to be taken, and that it is made without any connection with any other person or persons making proposal for the same article, and is in all respects fair and without collusion or fraud.

The bidder further declares that they have carefully examined the specifications and is thoroughly familiar with its provisions and with the quality, type and grade of materials required.

The bidder further declares that they have provided a discount on all factory options included in this bid, and such discount will be included in all purchase orders.

The bidder further declares that the company understands the financial responsibility associated with this bid as stated and further declares that it has the ability to meet the financial responsibility associated with this bid.

The bidder further declares that the company will furnish the items awarded for the price bid.

FSA Contract Number FSA22-VEL30.0

Bidder Company Name TRUCKMAX , INC

Business Address 6000 NW 77TH COURT, MIAMI, FLORIDA, 33166

Name of Authorized Agent GUILLERMO CHEZ

Email address of authorized agent MYTRUCKS101@GMAIL.COM

Signature

Date 08/04/2023



CONTRACT SIGNATURE FORM

By submitting a response to this Invitation to Bid and signing this form, the Bidder declares that he or she has read, and the company understands, accepts and will comply with the terms, conditions and specifications of this bid and any addenda issued. The failure or omission to review this document shall in no way relieve the authorized agent of obligations with respect to this bid. The submission of a bid and signature below shall be taken as evidence of acceptance of the terms and conditions of this bid.

The Bidder further declares that no other persons other than the authorized agent herein named has any interest in this bid or in the contract to be taken, and that it is made without any connection with any other person or persons making proposal for the same article, and is in all respects fair and without collusion or fraud.

The Bidder further declares that they have carefully examined the specifications and is thoroughly familiar with its provisions and with the quality, type and grade of materials required.

The Bidder further declares that they have provided a discount on all factory options included in this bid, and such discount will be included in all purchase orders.

The Bidder further declares that the company understands the financial responsibility associated with this bid as stated and further declares that it has the ability to meet the financial responsibility associated with this bid.

The Bidder further declares that the company will furnish the items awarded for the price bid.

FSA Contract Number FSA23-VEH21.0: Heavy Trucks & Buses

Bidder Company Name Truckworx

Business Address 461 Sand Mine Rd
DeFuniak Springs, FL 32435

Name of Authorized Agent Rebecca Herrington

Email address of authorized agent rebeccac@truckworx.com

Signature

Date 08/08/2023

FSA Contract Number FSA23-VEH21.0: Heavy Trucks & Buses
Bidder Company Name Truckworx

FSA Cooperative Purchasing Program



FSA23-VEH21.0: Heavy Trucks & Buses Terms & Conditions

FLORIDA SHERIFFS ASSOCIATION
Cooperative Purchasing Program
Contract Terms and Conditions

Table of Contents

1.0 GENERAL CONDITIONS..... 5

 1.01 BID CORRESPONDENCE..... 5

 1.02 PURPOSE 5

 1.03 TERM OF CONTRACT 5

 1.04 JURISDICTION 5

 1.05 SHERIFF AS COUNTY CONSTITUTIONAL OFFICER 5

 1.06 FUNDING 6

 1.07 CURRENCY 6

 1.08 GENERAL DEFINITIONS..... 6

 1.09 ELIGIBLE PURCHASERS OF CONTRACT 8

 1.10 LEGAL REQUIREMENTS 8

 1.11 PATENTS & ROYALTIES..... 9

 1.12 FEDERAL AND STATE STANDARDS 9

 1.13 UNDERWRITERS’ LABORATORIES 9

 1.14 AMERICANS WITH DISABILITIES ACT 9

 1.15 REASONABLE ACCOMMODATION 9

 1.16 DISADVANTAGED BUSINESSES..... 9

 1.17 ANTI-DISCRIMINATION 10

 1.18 BEST COMMERCIAL PRACTICES 10

 1.19 PUBLIC ENTITY CRIMES (PEC)..... 10

 1.20 TAX EXEMPTION..... 10

 1.21 ORDER OF PRECEDENCE IN THE EVENT OF CONFLICT 11

 1.22 COMMUNICATIONS 11

 1.23 CLARIFICATION AND ADDENDA 11

 1.24 SIGNED BID CONSIDERED AN OFFER 12

 1.25 ASSIGNMENT OF CONTRACT 12

 1.26 TERMINATION OF PRODUCT LINE..... 12

 1.27 DEMONSTRATION OF COMPETENCY 12

 1.28 VENDOR ABILITY TO PERFORM..... 13

FLORIDA SHERIFFS ASSOCIATION
Cooperative Purchasing Program
Contract Terms and Conditions

1.29	FINANCIAL RESPONSIBILITY	13
1.30	QUALITY AND SAFETY	13
1.31	NONCONFORMANCE	14
1.32	GRATUITIES	14
1.33	TIE BIDS	14
1.34	RIGHT TO AUDIT	14
1.35	LICENSES AND PERMITS	15
1.36	PERFORMANCE BONDS.....	15
1.37	ELIMINATION FROM CONSIDERATION	15
1.38	INDEPENDENT PREPARATION.....	15
1.39	DEFAULT	16
1.40	PROTESTS AND ARBITRATION.....	16
1.41	NONPERFORMANCE	17
1.42	SEVERABILITY	18
1.43	TERMINATION FOR CAUSE.....	18
1.44	TERMINATION WITHOUT CAUSE	18
1.45	CONTRACT ADVERTISEMENT AND USE OF FSA LOGO.....	19
2.0	BIDDER INSTRUCTIONS	20
2.01	QUALIFICATION.....	20
2.02	LICENSING AND FACILITIES	20
2.03	INSURANCE AND INDEMNIFICATION.....	21
2.04	SPECIFICATIONS	23
2.05	SEALED BIDS.....	23
2.06	MISTAKES	23
2.07	EXCEPTIONS	23
2.08	EQUIVALENTS.....	23
2.09	MANDATORY PRE-BID MEETING	24
2.10	PRICES QUOTED – HEAVY TRUCKS AND BUSES AND EQUIPMENT INVITATIONS TO BID 24	
2.11	PRICES QUOTED – PURSUIT, ADMINISTRATIVE AND OTHER VEHICLES INVITATION TO BID.....	24

FLORIDA SHERIFFS ASSOCIATION
Cooperative Purchasing Program
Contract Terms and Conditions

2.12 PURSUIT, ADMINISTRATIVE, AND OTHER VEHICLES CONTRACT COST-PLUS-PERCENT PRICING 25

2.13 OPTION PRICING – EQUIPMENT INVITATION TO BID 26

2.14 OPTION PRICING – HEAVY TRUCKS AND BUSES AND PURSUIT, ADMINISTRATIVE AND OTHER VEHICLES INVITATIONS TO BID 27

2.15 EMERGENCY LIGHTS AND SIRENS 28

2.16 BID SUBMISSION 29

2.17 ZONE BIDDING 30

2.18 EXECUTION OF BID 30

2.19 MODIFICATION OR WITHDRAWALS OF BIDS 30

2.20 LATE BIDS 30

2.21 BID OPENING 30

2.22 DETERMINATION OF RESPONSIVENESS 31

2.23 RESPONSIBLE BIDDER CRITERIA 31

2.24 BASIS FOR AWARD 31

2.25 BID TABULATIONS 32

2.26 MINOR IRREGULARITIES/RIGHT TO REJECT 32

2.27 CONE OF SILENCE 32

3.0 CONTRACT CONDITIONS 33

3.01 GENERAL REQUIREMENTS 33

3.02 STATEMENT OF AUTHORITY 33

3.03 VENDOR CONTACT INFORMATION 33

3.04 ADDITIONS OR DELETIONS 33

3.05 CONTRACT EXTENSION 33

3.06 PRICE ADJUSTMENT 34

3.07 CONDITIONS 34

3.08 PRODUCTION CUTOFF 35

3.09 FACILITIES 35

3.10 PURSUIT RATED VEHICLES & MOTORCYCLES 35

3.11 SPECIAL SERVICE VEHICLES 35

3.12 CAB AND CHASSIS PURCHASES 35

FLORIDA SHERIFFS ASSOCIATION
Cooperative Purchasing Program
Contract Terms and Conditions

3.13 FACTORY-INSTALLED OPTIONS 35

3.14 VENDOR-INSTALLED OPTIONS 36

3.15 NON-SCHEDULED OPTIONS 36

3.16 FORCE MAJEURE 36

3.17 PURCHASE ORDERS..... 36

3.18 REGISTRATION, TAG, AND TITLE 37

3.19 DELIVERY 37

3.20 INSPECTION AND ACCEPTANCE 38

3.21 INVOICING AND PAYMENTS..... 38

3.22 WARRANTY..... 39

3.23 QUARTERLY REPORTS 39

3.24 ADMINISTRATIVE FEE..... 39

3.25 LIQUIDATED DAMAGES..... 40

Appendix A: Zone Map..... 42

Appendix B. Bid Calendar..... 43

Appendix C: ACH Payments 45

Appendix D: Federal Clauses..... 46

FLORIDA SHERIFFS ASSOCIATION
Cooperative Purchasing Program
Contract Terms and Conditions

1.0 GENERAL CONDITIONS

1.01 BID CORRESPONDENCE

All correspondence regarding this bid should be directed to the Florida Sheriffs Association, "FSA". Please be sure to reference the bid number and title and provide your contact information. Communication for this Invitation to Bid should be identified by contract number and title and directed to:

Florida Sheriffs Association
Attn: Cooperative Purchasing Program Coordinator
2617 Mahan Drive
Tallahassee, FL 32308
E-mail: CPP@flsheriffs.org

1.02 PURPOSE

The Florida Sheriffs Association invites interested Bidders, including manufacturers and dealers or authorized representatives to submit responses in accordance with these solicitation documents. The FSA Cooperative Purchasing Program will conduct the solicitation process and administer the resulting contract. The purpose of this bid is to establish contracts with manufacturers and manufacturer's authorized dealers for contract terms specified under Section 1.03 for the purchase of items on a "no trade-in basis."

1.03 TERM OF CONTRACT

The term for Contracts FSA23-VEL31.0 Pursuit, Administrative and Other Vehicles and FSA23-VEH21.0 Heavy Trucks and Buses shall remain in effect for one year from date of contract execution by the FSA, and may be extended by mutual agreement, at the sole option and discretion of the FSA. The initial term of these contracts begins October 1, 2023, and ends September 30, 2024.

The term for Contract FSA23-EQU21.0 Equipment shall remain in effect for two years from date of contract execution by the FSA, and may be extended by mutual agreement, at the sole option and discretion of the FSA. The initial term of this contract begins October 1, 2023, and ends September 30, 2025.

Contract extensions will only be executed when the FSA determines, based on then-existing conditions, that it is in the best interest of the FSA and the purchasers to do so.

1.04 JURISDICTION

This Agreement shall be governed by and construed in accordance with the laws of the State of Florida. Venue shall lie in the appropriate court in and for Leon County, Florida.

1.05 SHERIFF AS COUNTY CONSTITUTIONAL OFFICER

The Offices of the Sheriff in the State of Florida are constitutional offices of the State of Florida. Each has the authority either individually or collectively to execute contracts for all goods and services for the proper conduct of that office. Section 30.53, Florida Statutes, exempts the sheriffs' offices from the provisions of the Florida Statute that would otherwise require sealed and competitive bidding procedures.

FLORIDA SHERIFFS ASSOCIATION

Cooperative Purchasing Program

Contract Terms and Conditions

The Office of the Sheriff is not required by law to accept the lowest priced proposal and may reject any or all of the proposals without recourse. Bidders are solely responsible for their own bid preparation costs and nothing in this solicitation in any way obligates the participating sheriffs' offices for any payment for any activity or costs incurred by any Bidder in responding to this solicitation.

1.06 FUNDING

In the case of certain purchasers, including state agencies, funds expended for the purposes of the contract must be appropriated by the Florida Legislature, the individual participating agency or the agency's appropriating authority for each fiscal year included within the contract period. For such agencies, their performances and obligations to pay for products or services under any resulting contract, or purchase order, are contingent upon such an annual appropriation by the Legislature, individual agency or by the appropriating authority. Therefore, any contract or purchase order with such an agency shall automatically terminate without penalty or termination costs in the event of non-appropriation.

1.07 CURRENCY

All transaction amounts, bids, quotes, provisions, payments or any part of this contract relating to currency are to be made in United States Dollars.

1.08 GENERAL DEFINITIONS

The terms used in this contract are defined as the following:

- A. **Base Specification:** Written descriptions of the minimum requirements for each item or item group developed by the FSA CPP for Bidders to bid on. These item requirements may be unique to FSA CPP and require additional components to the manufacturer's standard item.
- B. **Bid System:** The online forum used for the submission of bids and review of bid results for the specifications connected to this Invitation to Bid. VendorLink is the software used for this bid.
- C. **Bidder:** A bidder or enterprise that submits a formal bid to the Florida Sheriffs Association Cooperative Purchasing Program in accordance with the Florida Sheriffs Association Cooperative Purchasing Program Terms and Conditions. A bidder, that is not the manufacturer, must be authorized by the manufacturer to market and sell an item for which they are bidding.
- D. **Build sheet:** A document from the Bidder that confirms that the item submitted by Bidders meets or exceeds the FSA CPP Base Specification. Build sheets include, but are not limited to, the factory options list and door data plate information for vehicles that include details such as engine size and transmission, paint codes, production date, axle code, etc.
- E. **Dealer:** An enterprise authorized by the manufacturer to market, sell, provide, and service the items for the Florida Sheriffs Association Cooperative Purchasing Program. Dealers may be Vendor-owned and controlled, in whole or in part, or independently owned and controlled.
- F. **End User:** A term used to distinguish the person who ultimately uses or is intended to use a product or for whom a product is designed for use.

FLORIDA SHERIFFS ASSOCIATION

Cooperative Purchasing Program

Contract Terms and Conditions

- G. **Factory:** Refers to the manufacturer produced products.
- H. **Fleet Advisory Committee (committee):** An employee of a sheriff's office or other local governmental agency, or person who FSA CPP identifies as a subject matter expert who assists with the development of bid specifications and evaluation of bid responses. The committee makes recommendations to the FSA CPP and is not responsible for final awards.
- I. **Florida Sheriffs Association Cooperative Purchasing Program (FSA CPP):** The entity that administers the Invitation to Bid and contract administration functions for the resulting contract(s).
- J. **Invitation to Bid:** A competitive solicitation and award process established through the issuance of an invitation to Bidders, vendors, dealers and manufacturers to submit a price offer on a specific product to be provided. This term shall include the Bid Specifications available to Bidders on the Bid System and references to solicitation documents. The term shall not include requests for proposals, requests for quotes, requests for letters of interest, or the solicitation of purchase orders based on oral or written quotations.
- K. **Manufacturer:** The original producer or provider of items offered on this contract.
- L. **Manufacturer's Suggested Retail Price (MSRP):** Manufacturer's Suggested Retail Price (MSRP) represents the Manufacturer's recommended retail selling price, list price, published list price, or other usual and customary price that would be paid by the purchaser. The following are acceptable sources of current MSRPs and MSRP Lists for use in submission of the bid solicitation and the resulting contract:
 - a. Manufacturer's Computer Printouts
 - b. Chrome Systems, Inc.'s PC Carbook Plus and PC Carbook Fleet Edition
 - c. Manufacturer's Annual U.S. Price Book
 - d. Manufacturer's official website
- M. **Non-Scheduled Option:** Any optional new or unused component, feature or configuration that is not included or listed in the Base Specifications or options provided by the Vendor.
- N. **Production Cutoff:** A date used by manufacturers to notify vendors and dealers that the manufacturer has reached maximum capacity for orders or are discontinuing the production of an item. Vehicle manufacturers use this term when referring to any given model year for production.
- O. **Published List Price:** A standard "quantity of one" price currently available to government and educational purchasers, excluding cooperative or volume discounts.
- P. **Purchase Order:** A request for order from a purchaser to an awarded Vendor for an item that has been awarded on this contract. Purchase Orders placed using this contract formalize the terms and conditions of this contract under which a Vendor furnishes items to a purchaser.
- Q. **Purchaser:** A purchaser is an entity that seeks to obtain items awarded on this contract by meeting the eligible user criteria.
- R. **Qualification Packet:** This document contains the required forms, attestations, authorizations, and organizational information needed by Bidders to submit a successful and complete bid.

FLORIDA SHERIFFS ASSOCIATION

Cooperative Purchasing Program

Contract Terms and Conditions

- S. Terms & Conditions: This document, which serves as the governing Invitation to Bid and contract for the identified FSA CPP Invitation to Bid and resulting contract(s). Standard regulations, processes, procedures, and compliance requirements are identified herein. Bidders complete a qualification packet during the bid process indicating they agree to comply with the Terms & Conditions, and that this will serve as a contract for both parties, should the Bidder(s) receive award.
- T. Third Party Supplier: Businesses external to a Bidder or Vendor that provide products and services which contribute to the overall finished item in this contract. Third Party Suppliers are contractors under the direction and responsibility of the Bidder or Vendor.
- U. Vendor: The Bidder(s) that receive award, who agree to provide the contract items that meet the requirements and Base Specifications of the contract. The Vendor must agree to the Terms & Conditions, which will serve as the governing contract. If the Vendor is not the manufacturer, the Vendor must be authorized by the manufacturer to market, sell, provide, and service all awarded items.
- V. Vendor Installed: A product or service provided by the Vendor or other third party; not the factory.

1.09 ELIGIBLE PURCHASERS OF CONTRACT

Awarded bid contract prices, will be extended and guaranteed to the Florida Sheriffs Association, any unit of local government, political subdivision or agency of the State of Florida. This includes, but is not limited to counties, municipalities, sheriffs' offices, clerks, property appraisers, tax collectors, supervisors of elections, school boards or districts, water management districts, other special districts, police and fire departments, emergency response units, state universities and colleges, or other state, local or regional government entities within the State of Florida. Eligible purchaser also includes all Eligible Users as defined in F.A.C. 60A-1.001(2).

All purchasers are bound by applicable Federal and State law, local ordinances, rules and regulations for purchases made under this contract. Participating agencies cannot guarantee any order other than those ordered by the individual agency.

In addition, awarded bids can be extended and guaranteed to other entities, which can include out-of-state sales, in accordance with Vendors' individual manufacturers' agreements. Vendors that wish to extend contract pricing to entities other than those defined here are governed by their manufacturers' agreements and must agree to the Terms & Conditions.

1.10 LEGAL REQUIREMENTS

Federal, State, and local laws, ordinances, rules and regulations, including any applicable motor vehicle dealer laws, that in any manner affect the items covered herein apply. Lack of knowledge by the Bidder of applicable legal requirements will in no way be a cause for relief from responsibility.

Bidders have the option to certify that they are willing to accept purchase orders funded in whole or in part with federal funds. By opting in, Bidders certify that they are willing to comply with the requirements outlined in Appendix D upon receipt of a federally funded purchase order. This is not a requirement of the Invitation to Bid or contract. Bidders are not required to opt-in; however, they are required to indicate whether they will opt-in or opt-out of receiving federally funded purchase orders. FSA CPP has taken actions to provide and develop information, materials, and resources for Bidders, Vendors and purchasers that will assist in the use of federal funding with this

FLORIDA SHERIFFS ASSOCIATION

Cooperative Purchasing Program

Contract Terms and Conditions

contract. It is the responsibility of the purchaser to determine compliance for each Vendor, if they wish to use federal funds for purchase or intend to request reimbursements using federal funds.

1.11 PATENTS & ROYALTIES

The Bidder/Vendor, without exception, shall indemnify and hold harmless the Florida Sheriffs Association (FSA) and its employees from liability of any nature or kind, including costs and expenses for, or on account of, any copyrighted, patented, or unpatented invention, process, or article manufactured or used in the performance of the contract, including its use by the FSA or a purchaser.

If the Bidder/Vendor uses any design, device or materials covered by letters, patent, or copyright, it is mutually understood and agreed, without exception, that the bid prices shall include all royalties or costs in any way arising, directly or indirectly, from the use of such design, device, or materials in any way involved in the work.

1.12 FEDERAL AND STATE STANDARDS

It is the intent of FSA CPP that all specifications herein are in full and complete compliance with all Federal and State of Florida laws, requirements, and regulations applicable to the type and class of commodities and contractual services being provided.

In addition, any applicable Federal or State legal or regulatory requirements that become effective during the term of the Terms & Conditions, regarding the items and services specifications, safety, and environmental requirements shall immediately become a part of the Terms & Conditions. The Vendor shall meet or exceed any such requirements of the laws and regulations. If an apparent conflict exists, the Vendor shall contact the FSA CPP immediately.

1.13 UNDERWRITERS' LABORATORIES

Unless otherwise stipulated in the bid, all manufactured items and fabricated assemblies shall be Underwriters' Laboratories, or U.L., listed or re-examination listing where such has been established by U.L. for the item(s) offered and furnished.

1.14 AMERICANS WITH DISABILITIES ACT

To request this material in accessible format, sign language interpreters, information on access for persons with disabilities, or any accommodation to review any document or participate in any FSA sponsored proceeding, please contact FSA Human Resources at (850) 877-2165 five business days in advance to initiate your request. TTY users may also call the Florida Relay Service at 711.

1.15 REASONABLE ACCOMMODATION

In accordance with the Title II of the Americans with Disabilities Act, any person requiring an accommodation because of a disability at the bid opening must contact the FSA Human Resources at (850) 877-2165.

1.16 DISADVANTAGED BUSINESSES

As part of the solicitation process FSA CPP makes information publicly available to potentially qualified entities, and conducts additional outreach to qualified:

FLORIDA SHERIFFS ASSOCIATION

Cooperative Purchasing Program

Contract Terms and Conditions

- Small businesses,
- Minority-owned small businesses,
- Women-owned small business enterprises, and
- Disadvantaged business enterprises.

FSA CPP takes necessary affirmative steps to ensure that minority businesses, women's business enterprises, and labor surplus area firms are used, when possible, as recommended by 2 C.F.R. § 200.321. FSA CPP will:

- Evaluate whether small, minority, and women's businesses are potential sources,
- Place those qualified small and minority businesses and women's business enterprises on solicitation lists, and
- Search the Small Business Administration, Minority Business Development Agency, and Labor Surplus Area reports for additional potential sources.

Bidders self-certify in the qualification packet whether they meet the state and federal definitions of a small business, minority-owned small business, women-owned small business enterprise, and disadvantaged business.

1.17 ANTI-DISCRIMINATION

The Bidder certifies that they are in compliance as applicable by federal or state law with the non-discrimination clause contained in Section 202, Executive Order 11246, as amended by Executive Order 11375, relative to equal employment opportunity for all persons without regard to race, color, religion, sex or national origin.

1.18 BEST COMMERCIAL PRACTICES

The apparent silence or omission of any description from the specifications shall be regarded as meaning that only the best commercial practices, size, and design are to be used. All workmanship is to be first quality. All interpretations of this specification shall be upon the basis of this statement.

1.19 PUBLIC ENTITY CRIMES (PEC)

In accordance with the Public Entity Crimes Act, Section 287.133, Florida Statutes, a person or affiliate who has been placed on the convicted vendor list maintained by the State of Florida Department of Management Services following a conviction for public entity crimes may not submit a bid on a contract to provide any goods or services to a public entity, may not submit a bid on a contract with a public entity for the construction or repair of a public building or public work, may not submit bids on leases of real property to a public entity, may not be awarded or perform work as a vendor, supplier, sub-vendor, or consultant under a contract with a public entity, and may not transact business with any public entity in excess of the threshold amount provided in Section 287.017, Florida Statutes, for CATEGORY TWO for a period of 36 months from the date of being placed on the convicted vendor list.

1.20 TAX EXEMPTION

Purchasers making a purchase pursuant to the awarded bid are generally exempt from Federal Excise and State Sales Tax. It is the responsibility of the Vendor to verify that the purchaser is exempt by obtaining the purchaser's Federal Excise and State Taxes and Use Certificate Number.

The Florida Sheriffs Association is a 501(c)3 organization and is exempt from all Federal Excise and State Taxes. The FSA State Sales Tax and Use Certificate Number is 85-8012646919C-3.

FLORIDA SHERIFFS ASSOCIATION

Cooperative Purchasing Program

Contract Terms and Conditions

1.21 ORDER OF PRECEDENCE IN THE EVENT OF CONFLICT

In the event of conflict, the conflict may be resolved in the following order of priority (highest to lowest):

- Addenda to Contract Terms & Conditions, if issued
- Contract Conditions
- General Conditions
- Addenda to Bid Specifications, if issued
- Bid Specifications
- Bidder Instructions

1.22 COMMUNICATIONS

Communications between a Bidder, lobbyist or consultant and FSA are limited to matters of process or procedure and shall be made in writing to the FSA CPP Staff.

Bidders should not rely on representations, statements, or explanations other than those made in this Invitation to Bid or in any written addendum to this Invitation to Bid, and no oral representations, statements, or explanations shall be deemed to bind the FSA or eligible users.

1.23 CLARIFICATION AND ADDENDA

Any questions or clarifications concerning the Invitation to Bid shall be submitted to FSA CPP by e-mail to CPP@flsheriffs.org with the bid title and number referenced on all correspondence. Final questions must be received by the date for Request for Clarification stated on the Bid Calendar. Questions and answers will be posted to the FSA CPP website on the date indicated on the Bid Calendar. Questions received during the cone of silence date listed on the bid calendar will not be addressed, except as provided herein.

Interpretation of the specifications or any solicitation documents will **not** be made to the Bidder verbally, and if any verbal clarifications are provided, they are without legal effect. FSA CPP will make every attempt to e-mail updates to registered Bidders. However, posting to the FSA CPP website or the Bid System constitutes proper notice of addenda.

The FSA CPP shall issue a Formal Addendum if substantial changes that impact the submission of bids are required. Any such addenda shall be binding on the Bidder and shall become a part of the solicitation document. In the event of conflict with the original specifications, addenda shall govern to the extent specified. Subsequent Formal Addenda shall govern over prior Formal Addenda only to the extent specified. The FSA will not be responsible for any explanation or interpretation made verbally or in writing except those made through the posting of a Formal Addendum.

The bid submission constitutes acknowledgment of addenda to the Bid Specifications. Bids that fail to account for the specification addenda shall be determined to be nonresponsive; however, the FSA CPP may waive this requirement when in its best interest.

After the start of the contract term, FSA CPP will notify all Vendors of any addenda and will require acknowledgement of the new terms and conditions. If the Vendor does not agree to the new terms and conditions, the Vendor's award can be removed or replaced by another Vendor or qualified responsive bidder.

FLORIDA SHERIFFS ASSOCIATION

Cooperative Purchasing Program

Contract Terms and Conditions

1.24 SIGNED BID CONSIDERED AN OFFER

The signed bid shall be considered an offer on the part of the Bidder, which offer shall be deemed accepted upon approval by the FSA CPP. The bid submission must be signed by an authorized representative. Submission of a bid in the FSA CPP Bid System constitutes a signed bid for purposes of bid evaluation. An electronic signature may be used and shall have the same force and effect as a written signature.

1.25 ASSIGNMENT OF CONTRACT

No right or interest in this contract may be assigned, transferred, conveyed, sublet or otherwise disposed of, without prior written consent of the FSA CPP.

If the original Vendor sells or transfers all assets or the entire portion of the assets used to perform this contract, a successor-in-interest must perform all obligations under this contract. FSA CPP reserves the right to reject the acquiring entity as Vendor. A change of name agreement will not change the contractual obligations of the Vendor.

In the event a manufacturer reassigns the product line to an alternate company, the Vendor is required to notify the FSA CPP in writing of the change within 10 business days of the reassignment. If the Vendor is not already an approved FSA CPP Vendor, the alternate company is required to submit a Qualifications Packet to the FSA CPP to become an approved Vendor *prior to* conducting any qualified sales. FSA CPP may approve such assignments of existing or new vendors at its discretion. The Vendor is required to honor the contract pricing and all of the applicable Terms & Conditions throughout the remaining term of the contract.

1.26 TERMINATION OF PRODUCT LINE

If a Vendor terminates a product line (manufacturer or brand), the Vendor is required to notify the FSA CPP within 10 business days of the decision not to retain the product line. FSA CPP may remove the terminated products from the contract.

1.27 DEMONSTRATION OF COMPETENCY

Bidders must be able to demonstrate a good record of performance for a reasonable period of time, and have sufficient financial support, equipment and organization to ensure they can satisfactorily execute the services if awarded a contract under the terms and conditions herein stated.

The terms "equipment" and "organization" as used herein shall be construed to mean a fully equipped and well-established company in line with the best business practices in the industry and as determined by the FSA CPP.

The FSA CPP may consider any evidence available and may require submission of supporting documentation regarding the financial, technical and other qualifications and abilities of a Bidder, including past performance with the FSA CPP in making the award.

FSA CPP may inspect the Bidder's facility prior to the award of contract. Bids will only be considered from firms which are regularly engaged in the business of providing the goods or services described in this Invitation to Bid.

Information submitted in the bid may not be plagiarized and, except in the case of materials quoted from this solicitation or developed by the manufacturer, must be the original work of the individual or company that submits the bid for evaluation.

FLORIDA SHERIFFS ASSOCIATION

Cooperative Purchasing Program

Contract Terms and Conditions

1.28 VENDOR ABILITY TO PERFORM

The FSA CPP may require Bidders to show proof that they have been designated as authorized representatives of a manufacturer or supplier, which is the actual source of supply. In these instances, the FSA CPP may also require information from the source of supply regarding the quality, packaging and characteristics of the products. Any conflicts between this material information provided by the source of supply and the information contained in the bid submission may render the bid nonresponsive.

During the contract period, FSA CPP may review the Vendor's record of performance and may require submission of supporting documentation to ensure that the Vendor is providing sufficient financial support, equipment and organization.

If the FSA CPP determines that the Vendor no longer possesses the financial support, equipment and organization in order to comply with this section, FSA has the authority to immediately terminate the contract.

By responding to this Invitation to Bid, the Vendor warrants that, to the best of his or her knowledge, there is no pending or threatened action, proceeding, or investigation, or any other legal or financial condition, that would in any way prohibit, restrain, or diminish the Vendor's ability to satisfy the obligations of a resulting contract. The Vendor warrants that neither it nor any affiliate is currently on the convicted vendor list maintained pursuant to section 287.133 of the Florida Statutes, or on any similar list maintained by any other state or the federal government. The Vendor shall immediately notify the FSA CPP and purchaser in writing if its ability to perform is compromised in any manner during the term of the contract.

1.29 FINANCIAL RESPONSIBILITY

Bidder affirms by the submission of the bid and by signature on the contract signature form that the Bidder:

- Has fully read and understands the scope, nature, and quality of work to be performed or the services to be rendered under this bid and has adequate facilities and personnel to fulfill such requirements.
- Accepts the financial responsibility associated with this bid and declares that they have the access to capital (in the form of liquidity or credit lines) in order to meet the financial demands of such award.
- Has assessed the financial responsibility required to serve the contract as bid, including such details as the obligations to perform all items bid, zones bid, and quantities that could be ordered, as well as timing of payment from purchasers, which can be 45 calendar days from receipt of invoice.

1.30 QUALITY AND SAFETY

All materials used for the manufacture or construction of any supplies, materials or equipment covered by this bid shall be new. The items bid must be new, the latest model, of the best quality, and highest-grade workmanship that meet or exceed federal safety standards.

Items requiring certification should require certification of options in cases where non-certified options could result in the decertification of the original product or warranty. In all cases where options are not certified, the Vendor must disclose to the end user that the non-certified options are not required to be certified. All options must meet or exceed federal safety standards.

FLORIDA SHERIFFS ASSOCIATION

Cooperative Purchasing Program

Contract Terms and Conditions

1.31 NONCONFORMANCE

Items may be tested for conformance with specifications. Items delivered that do not conform to specifications may be rejected and returned at the Vendor's expense.

Any violation of these stipulations may also result in:

- Vendor's name being removed from the awarded vendor list.
- FSA and purchasers being advised not to do business with Vendor.

1.32 GRATUITIES

Bidders shall not offer any gratuities, favors, or anything of monetary value to any official, employee, or agent of the FSA, for the purpose of influencing consideration of this bid. Bidders shall disclose in writing any conflicts of interest to FSA prior to any award, or as soon as practicable after learning of any such conflict, including any contractual or employment relationships with FSA or potential purchasers of Bidders' products or services.

1.33 TIE BIDS

FSA CPP has the right to award multiple Bidders the primary or alternate award in the event of a tie. In the event the FSA CPP desires to break tie bids, and businesses have qualifying drug-free work programs, the award will be made using the following criteria:

- Bidder within the State of Florida
- Vendors' performance record with purchasers
- Coin Toss

1.34 RIGHT TO AUDIT

Vendor shall establish and maintain a reasonable accounting system that enables FSA CPP to readily identify Vendor's sales. FSA CPP and its authorized representatives shall have the right to audit and to make copies of all related records pertaining to this contract, including all government sales and eligible user information, whether kept by or under the control of the Vendor, including, but not limited to those kept by its employees, agents, assigns, successors, sub-vendors, or third-party suppliers in whatever form they may be kept – written or electronic. Such records shall include, but not be limited to:

- Accounting records, including but not limited to purchase orders, confirmation of orders or invoices, paid vouchers, cancelled checks, deposit slips, ledgers, and bank statements;
- Written policies and procedures;
- Subcontract files (including proposals of successful and unsuccessful Bidders, bid recaps, etc.);
- Original estimates, quotes, or work sheets;
- Contract amendments and change order files;
- Insurance documents; or
- Memoranda or correspondence.

Vendor shall maintain such records during the term of this contract and for a period of three (3) years after the completion of this contract. At the Vendor's expense and upon written notice from FSA CPP, the Vendor shall provide such records for inspection and audit by FSA CPP or its authorized representatives. Such records shall be made available to FSA CPP during normal business hours within three business days of receipt of the written notice. FSA CPP may select the Vendor's place of business or offsite location for the audit. The FSA CPP may also request the Vendor provide requested records via e-mail.

FLORIDA SHERIFFS ASSOCIATION

Cooperative Purchasing Program

Contract Terms and Conditions

Vendor shall ensure FSA has these rights with Vendor's employees, agents, assigns, successors, and third-party suppliers, and the obligations of these rights shall be explicitly included in any subcontracts or agreements formed between the Vendor and any sub-vendors to the extent that those subcontracts or agreements relate to fulfillment of the Vendor's obligations to FSA.

Professional fees, personnel costs and travel costs incurred by FSA under its authority to audit and not addressed elsewhere will be the responsibility of the FSA. However, if the audit identifies underreporting, overpricing or overcharges (of any nature) by the Vendor to FSA or a purchaser in excess of three percent (3%) of the total contract billings, the Vendor shall reimburse FSA for the total costs of the audit not to exceed \$5,000. If the audit discovers substantive findings related to fraud, misrepresentation, or non-performance, FSA may recoup all the costs of the audit work from the Vendor.

Any adjustments or payments that must be made as a result of any such audit or inspection of the Vendor's invoices or records shall be made within a reasonable amount of time (not to exceed 60 calendar days) from presentation of FSA's findings to Vendor.

FSA has the right to assess damages or seek reimbursements or refunds based on audit results.

1.35 LICENSES AND PERMITS

The Bidder shall obtain and pay for all licenses, permits and inspection fees for this bid submission and any resulting contract. Where Vendors are required to enter or go onto FSA or purchaser property to deliver materials or perform work or services as a result of a bid award, the Vendor will assume the full duty, obligation and expense of obtaining all necessary licenses, permits and insurance.

The Bidder must, by the time of award, be registered to do business in the State of Florida on SunBiz.gov.

1.36 PERFORMANCE BONDS

Purchasers may request a performance bond from a Vendor. Performance bonds are recommended with pre-payment and will be at the expense of the requesting agency. Purchasers should determine the best practice in comparing performance bond expense against any prior discounts that may be available.

1.37 ELIMINATION FROM CONSIDERATION

This Invitation to Bid shall not be awarded to any person or Bidder who has outstanding debts to the FSA, whether in relation to current or previous bid awards or for other business purposes.

1.38 INDEPENDENT PREPARATION

A Bidder shall not, directly or indirectly, collude, consult, communicate or agree with any other Bidder as to any matter related to the bid each is submitting. Additionally, a Bidder shall not induce any other Bidder to modify, withdraw, submit, or not submit a bid.

Bidders or Vendors who are found to have engaged in these acts will be considered nonresponsive and will be suspended or barred from bid participation. Any contract award resulting from these acts may be terminated for

FLORIDA SHERIFFS ASSOCIATION

Cooperative Purchasing Program

Contract Terms and Conditions

default. Further, any such acts detected by the FSA may be reported to relevant law enforcement and/or prosecutorial agencies.

Bidders may submit multiple bids without violating this provision if the bid submitted is not from the same manufacturer and product line. Dealers that share the same ownership may submit multiple bids without violating this provision if the Bidders are not in the same region featuring the same manufacturer and product line.

1.39 DEFAULT

In case of default on the part of Vendor, the FSA CPP may take necessary steps to otherwise procure the products sought, including but not limited to procuring the products or services from the next highest ranked Bidder or from other sources. A defaulting Vendor may be held liable for costs incurred by the FSA in procuring replacement products.

1.40 PROTESTS AND ARBITRATION

Any person who is adversely affected by the decision or intended decision to award shall file a "Notice of Protest" in writing to the FSA CPP within three (3) business days after the posting of the Intent to Award and shall file a formal written protest within five (5) business days after filing the Notice of Protest. Failure to file both a notice of protest and a formal written protest within the above referenced timelines shall constitute a waiver of proceedings.

The burden is on the party protesting the award of the bid to establish grounds for invalidating the award(s). The formal written protest must state with particularity the facts and law upon which the protest is based. Options are for informational purposes only and will not serve as a basis for protest. Failure to do so will result in a denial of protest. Formal written protest which states with particularity the facts and law upon which the protest is based will be reviewed by FSA legal counsel for legal soundness and validity, and corrective action will be taken as needed contingent upon the validity of such claims. However, any additional time required and cost incurred by the FSA to substantiate a protesting party's claim(s) beyond the normal scope of its legal review due to the vague or inconclusive nature of the protesting party's filing will be reimbursable to the FSA and deducted from the protesting party's bond or security which must accompany their filing.

Any Bidder who files an action protesting a decision or intended decision pertaining to this contract shall post a bond, cashier's check or money order payable to the Florida Sheriffs Association in the amount equal to ten percent of the item being protested. The bond, cashier's check or money order must be filed at the time of filing the formal written protest or within the five (5) business day period allowed for filing the formal written protest. FSA CPP will provide the amount required within two (2) business days of the notice of protest received. This bond or security will be conditioned upon the payment of all costs which may be adjudged against the protesting party in a court of law and/or to reimburse the FSA for additional legal expenses incurred and required to substantiate the protesting party's claim(s). Failure to post the bond or security requirement within the time allowed for filing will result in a denial of protest. The filing of the protest shall not stay the implementation of the bid award by the Florida Sheriffs Association.

Should the unsuccessful Bidder(s) decide to appeal the decision of the FSA, they shall file a notice to FSA CPP within three (3) business days of the FSA bid protest decision regarding their intent to request arbitration. A demand for arbitration with the American Arbitration Association's (AAA) commercial panel under its rules and regulations must be made within ten (10) business days of the FSA bid protest decision. Any person who files for an arbitration with the AAA shall post with the Florida Sheriffs Association at the time of filing the formal written arbitration request, a bond, cashier's check or money order payable to the Florida Sheriffs Association in the

FLORIDA SHERIFFS ASSOCIATION

Cooperative Purchasing Program

Contract Terms and Conditions

amount equal to ten percent of the product line being protested. This amount will be the same amount as the FSA CPP provided at the time of filing the initial protest. Failure to provide written notice to FSA CPP, file a demand for arbitration with the AAA, or failure to post the required bond and security requirement within the specified timelines shall constitute a waiver of arbitration proceedings. By responding to this procurement, the Bidder expressly agrees to the use of mandatory binding arbitration to resolve any appeals of the decision of the FSA, and any claims arising from or in any way relating to the procurement process, and expressly waives any and all rights that it may otherwise have to pursue such claims in any other forum, judicial or otherwise.

If the party filing for arbitration does not prevail, it shall pay all costs, legal expenses and attorney fees of the prevailing party incurred in connection with the arbitration. However, if the filing party prevails, the parties shall share equally the fees and expenses of the arbitration and AAA and each shall bear the cost of their own attorney fees. The filing for arbitration shall not stay the implementation of the bid award by the Florida Sheriffs Association.

1.41 NONPERFORMANCE

By virtue of the bid submission, Bidder acknowledges its obligation to sell items in all zones for which it is awarded. Upon award, failure of the Vendor to comply with these requirements may result in the imposition of liquidated damages of up to \$1,000 per item, which amount the Vendor agrees is reasonable, or probation, suspension, termination or a combination thereof from current and future bids at the FSA CPP's discretion.

The Vendor shall at all times during the contract term remain responsive and responsible. In determining Vendor's responsibility, the FSA CPP shall consider all information or evidence that demonstrates the Vendor's ability or willingness to fully satisfy the requirements of the Terms & Conditions.

Vendors that are not in compliance with any of the provisions of this contract can be assessed liquidated damages, suspended or terminated from the contract. The FSA CPP at its sole discretion may remove a noncompliant Vendor from future competitive bid solicitations; or take other actions including suspension from the contract until compliance issues are resolved, limit current or future vendor participation by items or zones, or other actions as determined by FSA CPP at its sole discretion.

At FSA CPP's discretion, Vendors may be required to develop corrective action plans to address contract compliance. Failure to abide by corrective action plans will result termination from the existing contract and future competitive bid solicitations at the discretion of the FSA CPP.

In situations where there is evidence that the Vendor has engaged in egregious breaches of the contract with respect to either the FSA CPP and/or the purchaser, the contract can be terminated and the Vendor will be removed from future solicitations for a period of up to three (3) years, or a permanent ban from the bid process at the sole discretion of FSA CPP.

Specific conditions for termination include, but are not limited to; failure to perform, refusal to accept orders during the contract period while manufacturer orders are still being accepted for current model year or the new year if the vehicle is price protected by the factory, charging amounts exceeding MSRP on factory or Vendor installed items and packages, requiring the purchase of additional options over and above the base vehicle as a condition of acceptance of order, providing aftermarket options where factory options are available without the consent of the purchaser, any misrepresentation of optional equipment or service as being factory that fails to meet the definition as described in this document, and any other practice deemed to be inconsistent with the intent of the contract.

FLORIDA SHERIFFS ASSOCIATION

Cooperative Purchasing Program

Contract Terms and Conditions

Any Vendor presented with a valid Purchase Order consistent with Vendor bid quotes or other agreed upon terms and pricing is required by this contract to accept such purchase order and deliver the product. Purchase Orders must be fulfilled whether or not the Purchase Order includes options. The Vendor must deliver this product in accordance with the Terms & Conditions – regardless of whether doing so will provide the Vendor with a profit or loss.

Failure to deliver the item may result in the purchaser seeking damages for the difference of cost to issue a new Purchase Order with another Vendor plus any legal fees and damages that may be incurred in the process to facilitate a completed order. Additionally, FSA CPP may seek damages for nonpayment of administrative fees, to which FSA CPP is entitled, according to Section 3.28, and any attorney's fees incurred in the recovery of these damages.

1.42 SEVERABILITY

In the event any provision of this contract is held to be unenforceable for any reason, the unenforceability thereof shall not affect the remainder of the contract, which shall remain in full force and effect and enforceable in accordance with its terms.

1.43 TERMINATION FOR CAUSE

If through any cause within the reasonable control of the Vendor, it shall fail to fulfill in a timely manner, or otherwise violate any of the terms of this contract, the FSA CPP shall have the right to terminate the services remaining to be performed. Written notice of the deficiencies shall be given to the Vendor and unless the deficiencies are corrected within 10 business days, the contract may be terminated for cause immediately. The right to exercise the option to terminate for cause shall be in the sole discretion of the FSA CPP, and the failure to exercise such right shall not be deemed to constitute a waiver of this right.

In the event of a termination for cause, the purchaser shall compensate the successful Bidder in accordance with the contract for all services performed by the successful Bidder prior to termination, net of any costs incurred by the purchaser and FSA as a consequence of the default.

Notwithstanding the above, the Vendor shall not be relieved of liability to the FSA for damages sustained by the FSA by virtue of any breach of the contract by the Vendor, and the FSA CPP may reasonably withhold payments to the Vendor for the purposes of offset until such time as the exact amount of damages due the FSA from the Vendor is determined.

1.44 TERMINATION WITHOUT CAUSE

The FSA CPP can terminate the contract in whole or part without cause by giving written notice to the Vendor of such termination, which shall become effective 30 calendar days following receipt by Vendor of such notice.

In the event of a termination without cause, all finished or unfinished documents and other materials shall be properly delivered to the FSA CPP.

The Vendor shall not furnish any product after it receives the notice of termination, except as necessary to complete the continued portion of the contract, if any. The Vendor shall not be entitled to recover any lost profits that the Vendor expected to earn on the balance of the contract or cancellation charges.

FLORIDA SHERIFFS ASSOCIATION
Cooperative Purchasing Program
Contract Terms and Conditions

Any payments to the Vendor shall be only to the total extent of the purchaser liability for goods or services delivered prior to the date of notice to terminate the contract.

1.45 CONTRACT ADVERTISEMENT AND USE OF FSA LOGO

The FSA logo is an official logo of the Florida Sheriffs Association designed to promote the program. The logo may be used by Vendors in accordance with this policy. Use of the logo is limited to the original version received from the FSA. Modifications are not permitted.

Methods of use include, but are not limited to:

- Electronic mediums such as websites, digital marketing campaigns, social media and e-mail; or
- Print media such as forms, marketing campaigns, business cards, posters, banners, brochures, flyers and postcards.

Vendors may request use of the logo by contacting cpp@flsheriffs.org, and should include a brief description of how the Vendor intends to use the logo. The official FSA sheriff's star and wreath logo may not be used without prior written permission.

FLORIDA SHERIFFS ASSOCIATION
Cooperative Purchasing Program
Contract Terms and Conditions

2.0 BIDDER INSTRUCTIONS

2.01 QUALIFICATION

Bidders are required to complete the qualification packet as part of the bid submission. A Bidder becomes a qualified bidder if they comply with this section and Section 2.11, Mandatory Pre-Bid Meeting.

Qualification Packet information required for bid qualification include:

- Qualification form
 - Contact Information
 - Business Profile
 - References
 - Disqualifications & Defaults
 - Warranty Service Plan Attestation
 - Emergency Technician Attestation
- Compliance Attestations
 - E-Verify
 - Drug-Free Workplace
 - Workers Compensation
 - Compliance with Applicable Federal, State, and Local Laws and Ordinances
- Federal Compliance
- If willing to comply with the requirements applicable to federally funded purchase orders, Federal Compliance Certifications
 - Certification Regarding Debarment and Suspension
 - Certification Regarding Lobbying
- Contract Signature Form
- Insurance Checklist
 - Certificates of Insurance due five days prior to award

The qualification packet is located on the Bid System.

2.02 LICENSING AND FACILITIES

Bidders are required to obtain all required licenses, including any applicable motor vehicle dealer licenses, and registrations, and comply with all applicable Federal, State, and local laws and ordinances, including any applicable motor vehicle dealer laws, in order to bid on any motor vehicle.

Bidders must maintain a repair facility within the State of Florida to provide warranty service for the items bid. If Bidders do not have a facility, the Bidder must be able to assist purchasers in obtaining warranty work as authorized by the manufacturer.

If a Bidder does not maintain a facility within the State of Florida, the Bidder must have a plan as to how the Bidder would service Florida purchasers if awarded the contract. This warranty service plan must demonstrate that the warranty work will be timely and satisfactorily performed and should include:

- Whether the warranty service provider is approved by the manufacturer;
- If the Bidder plans to contract out for service, a copy of the service agreement; and
- Zone specific service plans to include:
 - Response time to initial call from purchaser,

FLORIDA SHERIFFS ASSOCIATION

Cooperative Purchasing Program

Contract Terms and Conditions

- Number of personnel available to service the contract,
- Qualifications of personnel providing warranty work, and
- Any additional information that would detail how warranty service would be provided.

The sufficiency of the Warranty Service Plan may be evaluated by the FSA CPP. The FSA CPP reserves the right to request additional information from a Bidder regarding the facility during the solicitation and the term of the contract, if awarded. The FSA CPP may also exercise discretion in examining such facility as deemed necessary.

2.03 INSURANCE AND INDEMNIFICATION

Bidder/Vendor shall be fully liable for the actions of its agents, employees, partners, or third party suppliers and shall fully indemnify, defend, and hold harmless the Florida Sheriffs Association, the participating agencies, and their officers, agents, and employees from suits, actions, damages, and costs of every name and description, including legal counsels' fees, arising from or relating to personal injury and damage to real or personal tangible property alleged to be caused in whole or in part by Bidder/Vendor, its agents, employees, partners, or third party suppliers; provided, however, that the Bidder/Vendor shall not indemnify for that portion of any loss or damages resulting directly from the negligent acts or omissions of the Florida Sheriffs Association and participating agencies or proximately caused by intentional wrongful acts or omissions of the Florida Sheriffs Association and participating agencies.

The Florida Sheriffs Association and/or participating agencies shall give the Bidder/Vendor (2) the opportunity to take over and settle or defend any such action at Bidder's/Vendor's sole expense. When reasonable, the Florida Sheriffs Association will give the Bidder/Vendor written notice of an action or threatened action. Bidder/Vendor shall not be liable for any unreasonable cost, expense or compromise incurred by the Florida Sheriffs Association, or participating agencies, in any legal action without Bidder's prior written consent, which consent shall not be unreasonably withheld, conditioned, or delayed.

The Insurance Checklist summarizes the Bidder's/Vendor's insurance coverage obligations, if awarded. Certificates of Insurance, evidencing such coverages and endorsements as required herein, shall be provided no later than five (5) business days prior to the contract award date. The Vendor may not begin performance under the contract until such Certificates have been approved by the FSA CPP.

The certificate must state Bid Number and Title. FSA must be named as an additional insured for the duration of the contract.

The Vendor shall maintain comprehensive general liability insurance and general aggregate insurance in the amount and coverage levels specified on the Insurance Checklist.

The Vendor shall specifically and distinctly assume, and does so assume, all risks of damage or injury to property or persons used or employed on or in connection with the work and of all damage or injury to any person or property wherever located, resulting from any action or operation under the contract or in connection with the work. It is understood and agreed that at all times the Vendor is acting as an independent contractor. The Vendor shall be responsible for the work and every part thereof, and for all materials, tools, appliances and property of every description, used in connection with this particular contract. The Vendor at all times during the full duration of work under this contract, including extra work in connection with this contract, shall meet the requirements of this section.

The Vendor shall maintain automobile liability insurance including property damage covering all owned, non-owned, hired and scheduled automobiles, when used in connection with the delivery or service of this contract.

FLORIDA SHERIFFS ASSOCIATION
Cooperative Purchasing Program
Contract Terms and Conditions

The Vendor shall maintain insurance to cover garage operations in the amount specified on the Insurance Checklist when the garage is used to complete work on this contract.

All insurance policies shall be issued by companies authorized to do business under the laws of the State of Florida and these companies must have a rating of B+ or better per the AM Best Rating.

FSA CPP required insurance coverages must be maintained through the duration of the contract. Upon expiration of the required insurance, the Vendor must email updated certificates of insurance for as long a period as any work is still in progress. No change or cancellation in insurance shall be made without 30 calendar days written notice to the FSA CPP.

It is understood and agreed that all policies of insurance provided by the Vendor are primary coverage to any insurance or self-insurance the FSA possesses that may apply to a loss resulting from the work performed in this contract. All policies issued to cover the insurance requirements herein shall provide full coverage from the first dollar of exposure.

The liability insurance coverage shall extend to and include the following contractual indemnity and hold harmless agreement:

The Vendor hereby agrees to indemnify and hold harmless the FSA, a 501(c)3, its officers, agents, and employees from all claims for bodily injuries to the public and for all damages to the property per the insurance requirement under the specifications including costs of investigation, all expenses of litigation, including reasonable legal counsel fees and the cost of appeals arising out of any such claims or suits because of any and all acts of omission or commission of any by the Vendor, his agents, servants, or employees, or through the mere existence of the project under contract.

The foregoing indemnity agreement shall apply to any and all claims and suits other than claims and suits arising out of the sole and exclusive negligence of the FSA, its officers, agents, and employees, as determined by a court of competent jurisdiction.

The Vendor will notify the insurance agent without delay of the existence of the Hold Harmless Agreement contained within this contract and furnish a copy of the Hold Harmless Agreement to the insurance agent and carrier.

The Vendor will obtain and maintain contractual liability insurance in adequate limits for the sole purpose of protecting the FSA under the Hold Harmless Agreement from any and all claims arising out of this contractual operation.

The Vendor will secure and maintain policies of third-party suppliers. All policies shall be made available to the FSA upon demand. Compliance by the Vendor and all third-party suppliers with the foregoing requirements as to carrying insurance and furnishing copies of the insurance policies shall not relieve the Vendor and all third-party suppliers of their liabilities and obligations under any section or provisions of this contract. Vendor shall be as fully responsible to the FSA for the acts and omissions of the third-party suppliers and of persons employed by them as they are for acts and omissions of persons directly employed by the Vendor.

The FSA can request, and the Vendor shall furnish proof of insurance within seven (7) calendar days of receipt of the written request from FSA. Should the Vendor fail to provide acceptable evidence of current insurance during the contract term, the FSA CPP shall have the right to consider the contract breached and justifying the

FLORIDA SHERIFFS ASSOCIATION

Cooperative Purchasing Program

Contract Terms and Conditions

termination thereof. If Bidder does not meet the insurance requirements; the FSA may consider alternate insurance coverage.

2.04 SPECIFICATIONS

All items covered by this Invitation to Bid and any resulting contract, and the specifications shall be the manufacturer's current basic production model, and shall, as a minimum, be equipped with all standard factory equipment in accordance with the manufacturer's latest literature unless otherwise noted in the Bid System or FSA CPP item group specification.

The Base Item Specifications are contained in the FSA CPP Bid System, may be requested from FSA CPP, and are retained within FSA CPP's archive. As part of the bid submission, Bidders will be required to provide confirmation that the item bid meets the FSA CPP Base Specification. FSA CPP may reject bids that fail to provide confirmation that the item(s) bid meet the FSA CPP Bid Specifications.

FSA CPP develops the specifications with subject matter experts and publicly available information. However, FSA CPP does not have access to full details from the manufacturer and relies on Bidders to assist in this process. Bidders should immediately notify the FSA CPP of any inaccuracies in the specifications. All notifications of inaccuracies must be in writing.

If awarded a contract, Vendor(s) must offer and supply an item that either meets or exceeds all the requirements included in the applicable Bid Specifications, unless a purchaser specifically issues a Purchase Order for a base item and Option that differs from the Base Specifications. Failure of a Bidder to comply with these provisions will result in Bidders being held responsible for all costs required to bring the item into compliance with the contract specifications.

2.05 SEALED BIDS

For purposes of this solicitation, a sealed bid is considered a bid submitted using the FSA CPP Bid System.

2.06 MISTAKES

Bidders are expected to examine the Base Item specifications, delivery schedules, bid prices and all information pertaining to servicing this contract before submitting a bid. Failure to do so will be at the Bidder's risk.

2.07 EXCEPTIONS

Any requested exceptions, deviations, or contingencies a Bidder may have to the Terms & Conditions must be documented in Bidder's submission. Exceptions to the Base Specifications at the time of the bid submission shall reference the item number, make and model. FSA CPP has the discretion to grant or deny, in whole or in part, the Bidder's requested exception, deviation or contingency to the specifications or Terms & Conditions. Bidder acknowledges that the bid may be disqualified if FSA CPP rejects the proposed exceptions.

2.08 EQUIVALENTS

Prior to the opening of the Bid System, Bidders may request item equivalents. The Bidder must submit the manufacturer name and model number (or product identifier) of each equivalent requested to FSA CPP. Complete,

FLORIDA SHERIFFS ASSOCIATION

Cooperative Purchasing Program

Contract Terms and Conditions

descriptive, technical literature should demonstrate that the equivalent conforms with specification. If a bid uses equivalents without prior approval, the bid may be disqualified.

2.09 MANDATORY PRE-BID MEETING

Prospective Bidders are required to attend or participate in the **mandatory** Pre-Bid Meeting. The Pre-Bid Meeting is designed for vendors, the Fleet Advisory Committee and the FSA CPP to clarify questions on the Terms & Conditions and to confirm all Base Item specifications. Questions relating to the items, specifications, the bid process, or award can be asked at the Pre-Bid Meeting. Bidders have the opportunity to suggest technical modifications or corrections before the Base Item specifications are finalized.

FSA CPP reserves the right to grant attendance exceptions to the mandatory meeting if the Bidder has requested authorization, agrees in writing to meet all the Terms & Conditions without exception and further waives their right to protest the bid process in its entirety or any portion thereof.

2.10 PRICES QUOTED – HEAVY TRUCKS AND BUSES AND EQUIPMENT INVITATIONS TO BID

Items and options should reflect the most complete price and be below MSRP and at a minimum should cover the cost of the item or option bid.

Prices quoted in the bid submission should reflect the final amount the Bidder can expect to receive for payment for the items bid for the duration of the contract, unless otherwise provided in the contract. Prices submitted as indicated in the sealed bid are final. Bidders acknowledge that prices quoted will be valid for a period of sixty (60) calendar days from the date of bid opening.

Each item, make, and model must be priced and bid separately. Prices must be inclusive of all the components included in the Base Specification.

Prices bid must include the administrative fee FSA CPP charges to administer the contract, as outlined in these Terms & Conditions. The administrative fee is three quarters of one percent (.0075).

Prices bid must be at least cost, be Free On Board (FOB) destination, and must include delivery to the purchaser.

Upon award, the Vendor has the authority to offer additional discounts based on prompt payment, quantity, as well as additional manufacturer or vendor discounts.

2.11 PRICES QUOTED – PURSUIT, ADMINISTRATIVE AND OTHER VEHICLES INVITATION TO BID

Due to the changing market conditions, the FSA CPP has temporarily moved to a percent above cost, or “cost-plus”, model for the Pursuit, Administrative and Other Vehicles Contract. The cost-plus model allows for Vendors to sell items immediately when order windows open up for next year’s model, when the manufacturer changes price during the contract term, or when new items come to market.

Bidders shall provide a Bid Price and a Percent for each item bid. The Bid Price will be used to evaluate the lowest, responsive and responsible Bidder for each item and zone. The Percent will be used under an awarded contract to determine the cost-plus pricing for new year’s models, when the manufacturer changes price during the contract

FLORIDA SHERIFFS ASSOCIATION

Cooperative Purchasing Program

Contract Terms and Conditions

term, or when new items come to market. The FSA CPP will use the percent feature of the Bid System as the field to capture the percent above cost that the Vendor can expect to receive from the purchaser for the purchase of an awarded item.

The FSA CPP has the discretion to disqualify Bidders if the proposed Percent is excessive. In order to determine if Percent is excessive, FSA will compare the Percents proposed by Bidders for each item in each zone.

Prices and Percents bid for items and options should reflect the most complete item price, be below MSRP, and at a minimum should at least cover the cost of the item or option bid.

Prices and Percents bid must be at least "Item Cost", be Free On Board (FOB) destination, and must include delivery to the purchaser.

As used in this provision, "Item Cost" is defined as the factory invoice price for the item, the Original Equipment Manufacturer (OEM) destination and delivery to dealer, and the FSA Administrative fee, minus the OEM government pricing concessions specific to this bid, all manufacturer incentives, discounts, rebates, concessions and holdbacks.

As used in this provision, "Total Cost" is defined as the Item Cost, plus costs of dealer's floorplan estimated operational expense, and costs of dealer for preparation, cleaning, and assembling, gas, and delivery to zone.

As used in this provision, "Bid Price" is defined as the Total Cost and profit.

As used in this provision, "Percent" is defined as the markup over Item Cost.

Bid Prices will be used as the initial publish pricing for awarded items. As windows open up for next year's model, the manufacturer changes price during the contract term, or as new items come to market, FSA CPP will work with Vendors to update the published pricing for such items based on the awarded Percent, within a reasonable period of time. Vendors may accept Purchase Orders for such items in accordance with these Terms & Conditions before submitting updated published pricing to FSA CPP.

2.12 PURSUIT, ADMINISTRATIVE, AND OTHER VEHICLES CONTRACT COST-PLUS-PERCENT PRICING

Due to the changing market conditions, the FSA CPP has temporarily moved to a percent above cost, or "cost-plus", model for the Pursuit, Administrative and Other Vehicles Contract. The cost-plus model allows for Vendors to sell items immediately when order windows open up for next year's model, when the manufacturer changes price during the contract term, or when new items come to market.

The Bid System provides each Vendors' percent above cost at which the Vendor will sell such items. The Percent provided in the Bid System does not provide a percent discount for items bid.

If Vendor fulfills a Purchase Order at other than published pricing, at purchasers' request, Vendor must provide documentation substantiating the Item Cost, as defined in section 2.11.

FLORIDA SHERIFFS ASSOCIATION
Cooperative Purchasing Program
Contract Terms and Conditions

2.13 OPTION PRICING – EQUIPMENT INVITATION TO BID

The Bidder shall offer discount below Manufacturer’s Standard Retail Pricing (MSRP) or manufacturers published list price for any factory options included in the bid submission and quotes to purchasers, if awarded. FSA CPP requests Vendors include most frequently purchased scheduled, factory and aftermarket options in the bid.

Options are intended to add or delete equipment or features from the Base Specification. Options can provide an upgrade or downgrade to a manufacturer’s model, such as a slightly different engine size or horsepower, and should not be made available for purchase separate from the base vehicle or equipment. Options may only provide a downgrade to a manufacturer’s model when specifically requested in a Purchase Order issued in accordance with the Terms & Conditions by a purchaser. Bidders shall NOT use options to create equipment that is entirely different than the FSA CPP Base Specification or are available as another specification bid on this Invitation to Bid.

Bidder must use proper factory codes for all factory options. Options available through the factory may be bid and supplied to purchaser as “factory” options, unless otherwise requested in writing by the purchaser.

The FSA CPP has the discretion to disqualify Bidders if the option pricing is excessive or if options listed are not available for the item bid. In order to determine if pricing is excessive, Bidders agree to provide documentation to FSA CPP to verify cost at any time during the solicitation process or during the contract term. This information is for comparison purposes only when determining if pricing is excessive and will not be published.

Option pricing will include all costs of labor associated with the option and cost of labor should not be listed separately within the bid. For purposes of this bid, Emergency Lights and Sirens will require a separate pricing sheet upload in the Bid System. Section 2.15 contains specific instructions and exceptions for Emergency Lights and Sirens.

If a Bidder will offer registration and title services as a fee for service, the Bidder must include the administrative fee as a separate option (i.e., line item) for each item bid. See Section 3.21 for additional details. Government imposed fees should not be included in this option pricing.

No other additional charges or fees are admissible.

If options are not available as a stand-alone option, the Bidder must indicate in their bid submission any option requiring the purchase of other options, and also indicate options that are a part or dependent of another option. Factory package options are allowable under this contract. Factory package options must be included in the options within the bid document and detailed specifically as to what components the package includes.

When calculating the price for a manufacturer’s option requested in this bid that is not listed as an option in the manufacturer’s order guide (i.e., model or engine upgrade), the Bidder must calculate the option price as the net difference between vendor cost on the representative base vehicle and the total MSRP of the requested option modifying the vehicle. A Bidder may bid less than this price, but at no time charge more than the calculation provided here.

The use of options to facilitate the sale of an alternate manufacturer’s product which is outside the scope of the written Base Specification will be determined nonresponsive and the bid will be rejected in whole or part by the FSA CPP.

Example: Bidder CANNOT include option upgrades that result in the selling of a vehicle or truck on one specification that is offered as a separate specification in

FLORIDA SHERIFFS ASSOCIATION

Cooperative Purchasing Program

Contract Terms and Conditions

the Invitation to Bid. For example, a Vendor who is awarded the bid for 25,500 lb. GVWR Cab & Chassis cannot upgrade this item through an add option to a 30,000 lb. GVWR Cab & Chassis in order to circumvent the bid award winner for the 30,000 lb. GVWR Cab & Chassis.

Purchasers are encouraged to negotiate option pricing with Vendors. Discounts can be provided beyond option prices listed in the contract. The additional discounts for each add option shall be decided by the Vendor.

The options will correspond to the specification or item number. Multiple options may be listed for each specification or item number bid. Therefore, Bidders that do not indicate the correct item number with the option information bid will not have options displayed for the item bid. If option pricing is not uploaded correctly, FSA CPP may require Bidders to correct the formatting of the options, but pricing may not be modified. Failure of the Bidder to make corrections may cause the bid to be rejected.

If the Bidder wishes to offer credit to the purchaser for an option that is standard on the FSA CPP Base Specification, the Bidder should include the word "Credit" at the beginning of the description and continue to describe the option being credited. For example, "Credit: one key fob" that corresponds with the price the Bidder will credit the purchaser.

Loose Equipment can be bid as an option and made available to purchasers for items originally purchased from this contract. For purposes of this provision, "Loose Equipment" is any item of equipment that attaches to the heavy equipment item(s) included in the awarded bid, such as different sized blades. Loose Equipment does not include accessories, such as additional keys.

2.14 OPTION PRICING – HEAVY TRUCKS AND BUSES AND PURSUIT, ADMINISTRATIVE AND OTHER VEHICLES INVITATIONS TO BID

FSA CPP requests Bidders include most frequently purchased options in the Bid System. Option pricing must include the administrative fee. Bidders must provide a price for each option in addition to a percent below MSRP for factory-installed options or a percent above cost for other options.

The FSA CPP has the discretion to disqualify Bidders if the option pricing is excessive. In order to determine if pricing is excessive, Bidders agree to provide documentation to FSA CPP to verify cost at any time during the solicitation process or during the contract term. This information is for comparison purposes and will not be published.

Options are intended to add or delete equipment or features from the Base Specification. Options can provide an upgrade or downgrade to a manufacturer's model, such as a slightly different engine size or horsepower, and should not be made available for purchase separate from the base vehicle or equipment. Options may only provide a downgrade to a manufacturer's model when specifically requested in a Purchase Order issued in accordance with the Terms & Conditions by a purchaser. Bidders shall NOT use options to create an item that is available as another item bid on this Invitation to Bid. The use of options to facilitate the sale of an alternate manufacturer's product which is outside the scope of the Base Specification will be determined nonresponsive and the bid will be rejected in whole or part by the FSA CPP. Bidders must disclose which options require the purchase of other options or are dependent on another option in their bid submission. Option pricing will include all costs of labor associated with the option and cost of labor should not be listed separately.

Bidder must use proper manufacturer codes for factory options. Options available through the factory should be bid and supplied to purchaser as factory options, unless otherwise requested in writing by the purchaser. Factory

FLORIDA SHERIFFS ASSOCIATION

Cooperative Purchasing Program

Contract Terms and Conditions

package options are permitted under this contract. Factory package options included in the bid submission must detail what components the package includes.

If a Bidder will offer registration and title services as a fee for service, government-imposed fees should be listed at the exact cost and shall not include the FSA administrative fee.

If the Bidder wishes to offer credit to the purchaser for an option that is standard on the FSA CPP Base Specification, the Bidder should include the word "Credit" at the beginning of the description field and continue to describe the option being credited. For example, "Credit: one key fob" and enter the price the Bidder will credit the purchaser.

For purposes of this bid, Emergency Lights and Sirens will require a separate pricing sheet and option upload in the Bid System. Section 2.15 contains specific instructions and exceptions for Emergency Lights and Sirens.

2.15 EMERGENCY LIGHTS AND SIRENS

Under Florida Statute 316.003(1), authorized emergency vehicles are defined as:

Vehicles of the fire department (fire patrol), police vehicles, and such ambulances and emergency vehicles of municipal departments, public service corporations operated by private corporations, the Fish and Wildlife Conservation Commission, the Department of Environmental Protection, the Department of Health, the Department of Transportation, and the Department of Corrections as are designated or authorized by their respective departments or the chief of police of an incorporated city or any sheriff of any of the various counties.

Bidders that will provide or contract to provide emergency light and siren installation must only use installers that possess a current Emergency Vehicle Technician Certification, or an approved equivalent. FSA CPP may request certificates for a Vendor's installers at any time during the contract term. Labor may be charged for the installation of emergency lights and sirens. Labor rates must be disclosed as part of the bid submission. Bidders may not charge for labor for vehicles that are manufactured with emergency lights and sirens, including motorcycles. Prices submitted for emergency lights and sirens shall include all applicable government-imposed fees.

Bidders that install emergency lights and sirens are required to provide and install products that are Society of Automotive Engineers (SAE) certified. SAE Certifications must include Class 1, Class 2 and Class 3 in order to be eligible for participation in the contract. If a lighting or siren product installed on an emergency vehicle is not SAE Certified, the Vendor can be found in default of the contract.

Bid Submission of Emergency Lights and Sirens

If offering emergency lights and sirens, Bidders will be asked to provide pricing by submitting a pricing sheet. An emergency vehicle lights and siren option pricing template is offered in the Bid System. Bidders are encouraged, but not required to use the template. If item or specification group is helpful to display light and siren options, Bidders may categorize the pricing sheet by item group.

Items listed below are required for the submission of the pricing sheet:

- Order code
- Description
- Price (part only)

FLORIDA SHERIFFS ASSOCIATION

Cooperative Purchasing Program

Contract Terms and Conditions

- Estimated labor hours
- Labor cost per hour

2.16 BID SUBMISSION

Bidders must submit a bid electronically using the Bid System. Bid submissions include a price for each item and option bid in accordance with Section 2.10, 2.11, 2.13, 2.14, and 2.15. Each Bidder must submit a qualifications package for each bid. The bid must be received by the date and time specified on the Bid Calendar in Appendix B. Failure to meet all submission requirements by the date indicated on the Bid Calendar will result in rejection of the bid.

Bid System: VendorLink

The Bid System is located at <https://www.myvendorlink.com>. Bidders are encouraged to participate in training provided. Usernames and passwords will be issued to Bidders after registering in the Bid System. Contact VendorLink at support@evendorlink.com if technical issues arise during bid submission.

Prices are to be rounded to the nearest whole dollar. If a Bidder submits bid pricing using cents, the following formula will be applied to round the bid pricing to the nearest whole dollar: \$.01-.49 will be rounded down to the dollar bid (e.g., \$50.49 = \$50) and \$.50-.99 will be rounded to the next dollar (e.g., \$50.50 = \$51).

Bid Submission

To ensure correct bid submittal and formatting, Bidders shall:

- For the Heavy Trucks and Buses Invitation to Bid, insert a:
 - Price for each item bid by zone
- For the Pursuit, Administrative and Other Vehicles Invitation to Bid, insert a:
 - Bid Price for each item bid by zone, as defined in Section 2.11
 - Percent for each item bid by zone, as defined in Section 2.11
- For the Equipment Invitation to Bid, insert a:
 - Price for each item by zone
- Upload files as instructed in the Bid System; files requested will be in Excel or .pdf.
- Follow all instructions outlined in this Invitation to Bid and provide all requested information.

The bid shall include the following documents:

- Executed Qualifications Packet.
- Build sheet for each item bid as a single .pdf
- Pricing Sheet for Emergency Vehicle Lights and Sirens, if applicable.
- Any requested exceptions or equivalents.

Option Upload

An option sheet should be submitted for each item bid. The Bid System will accept option information for each item through a .pdf file upload. Each option sheet should include a header to identify the FSA CPP contract title and number, the Bidder name, item number, make and model. Each option sheet should include:

- Option
- Description
- Manufacturer order code or identifying code
- Price

For the Heavy Trucks and Buses and Pursuit, Administrative, and Other Vehicles Invitations to Bid, the option sheet should also include:

FLORIDA SHERIFFS ASSOCIATION

Cooperative Purchasing Program

Contract Terms and Conditions

- Cost plus percent for all items not installed at the factory
- Percent below MSRP for factory installed options

FSA CPP may ask awarded Bidders to supply one hard copy set with digital signatures and original compliance forms, prior to the contract execution. Hard copy bids should not be submitted unless specifically requested by FSA CPP. FSA is not responsible for Bidder's improper use of the Bid System. Exceptions will be granted to this section should any Bid System malfunctions occur.

2.17 ZONE BIDDING

Bidders may bid in one or more geographic zones. Bidders must submit pricing for each zone they wish to be evaluated. The zone map is included in Appendix A. The geographic zones are in place to assist Bidders in estimating costs of delivery, which must be included in the price bid and quoted to the purchaser. For the Pursuit, Administrative and Other Vehicles Contract, the cost of delivery must be included in the Percent.

2.18 EXECUTION OF BID

By submitting a response to this Invitation to Bid, the Bidder agrees to the Terms & Conditions and to be bound by such Terms & Conditions if selected for award. The Bidder must submit the Contract Signature Form with the signature of an authorized representative no later than the bid submittal due date. All Terms & Conditions are applicable throughout the term of the awarded contract and are not specific to any given year, make or model.

2.19 MODIFICATION OR WITHDRAWALS OF BIDS

A Bidder may submit a modified bid to replace all or any portion of a previously submitted bid until the due date and time of the bid submission listed in the Bid Calendar. Modifications received after the bid due date and time will not be considered.

Bids can be withdrawn in writing prior to the contract award. If a Bidder must withdraw the bid, the Bidder must contact FSA CPP immediately. Bid withdrawals are handled on a case-by-case basis and can result in a limitation of participation in future bids.

2.20 LATE BIDS

The responsibility for submitting a bid before the due date and time on the bid calendar is solely and strictly the responsibility of the Bidder. The FSA is not responsible for delays caused by technical problems, any internet outages or delays incurred by electronic delivery, or any other occurrence. Any reference to time will be based on Eastern Time.

2.21 BID OPENING

Bids shall be opened on the date and time specified on the Bid Calendar. The bid opening may occur at the Florida Sheriffs Association, 2617 Mahan Drive, Tallahassee, Florida, or may be offered online.

FSA CPP will provide a bid inspection period for Bidders following the bid opening. The date, time and duration will be announced prior to the bid opening.

FLORIDA SHERIFFS ASSOCIATION
Cooperative Purchasing Program
Contract Terms and Conditions

2.22 DETERMINATION OF RESPONSIVENESS

Determination of responsiveness will take place at the time of bid opening and evaluation. In order to be deemed a responsive bidder, the bid must conform in all material respects to the requirements stated in the Invitation to Bid. As set forth in Section 2.26, FSA CPP reserves the right to waive or allow a Bidder to correct minor irregularities.

2.23 RESPONSIBLE BIDDER CRITERIA

Bids will be evaluated to determine if qualifications and contract requirements are met. Responses that do not meet all requirements of this Invitation to Bid or fail to provide all required information, documents or materials may be rejected as nonresponsive. The FSA CPP will not request documentation or consider a Bidder's social, political or ideological interests in determining if the Bidder is a responsible bidder. FSA CPP will not give preference to a Bidder based on the Bidder's social, political, or ideological interests.

Bidders whose responses, past performance, or current status do not reflect the capability, integrity, or reliability to fully and in good faith perform the requirements of the contract may be rejected as non-responsible. In determining a responsible Bidder, the following factors may be considered:

- Adequacy of facilities, staffing, and financial resources;
- Previous experience with FSA contract or other similar government contracts;
- Ability to provide excellent customer service, including on previous FSA contracts; and
- Any other information relevant to the responsibility of a Bidder of which FSA CPP is aware.

In addition to the requirements set forth by these Terms & Conditions, FSA CPP reserves the right to request staffing, performance and financial information from any Bidder during the evaluation process.

FSA CPP reserves the right to determine which responses meet the requirements, specifications, Terms & Conditions of the solicitation, and which Bidders are responsive and responsible.

FSA CPP further reserves the right to limit participation of Bidders who, in FSA CPP's sole discretion, are determined to present responsibility concerns that call into question the Bidder's ability to perform but that do not rise to the level of requiring rejection of the Bidder as non-responsible.

2.24 BASIS FOR AWARD

For the Heavy Trucks and Buses, and Equipment Invitations to Bid, the FSA CPP shall make awards to the qualified, responsive and responsible Bidder(s) who submitted the lowest priced bid by item, manufacturer, and zone. Awards may also be made to subsequent lowest responsive and responsible Bidders by item, manufacturer, and zone, when determined to be in the best interest of the FSA and the purchaser(s). FSA CPP has the discretion to consider option pricing in making the award and to disqualify Bidders for proposing excessive option pricing.

For the Pursuit, Administrative and Other Vehicles Invitation to Bid, the FSA CPP shall make award to the qualified, responsive and responsible Bidder(s) who submitted the lowest Bid Price by item, manufacturer, and zone. Awards may also be made to subsequent lowest responsive and responsible Bidders by item, manufacturer, and zone, when determined to be in the best interest of the FSA and the purchaser(s). FSA CPP has the discretion to consider Percent and option pricing in making the award and to disqualify bidders for proposing excessive Percent(s) or option pricing.

FLORIDA SHERIFFS ASSOCIATION

Cooperative Purchasing Program

Contract Terms and Conditions

Awards will not be given to any parties listed on the government wide exclusion in the System for Award Management.

FSA CPP reserves the right to accept or reject any and all bids, and to waive any minor irregularity, technicality or omission if it determines that doing so will serve the purchaser's best interest. FSA CPP reserves the right to make multiple awards for each item, if determined to be in the best interest of the FSA and the purchasers.

Awards will be posted on the FSA CPP website according to the date posted in the bid calendar.

2.25 BID TABULATIONS

The Bid Tabulation report will be posted on the FSA CPP website after the bid submission closes.

If there is a delay in posting the bid tabulation results, FSA CPP will post a notice of the delay and a revised date for posting of results.

2.26 MINOR IRREGULARITIES/RIGHT TO REJECT

The FSA CPP has the right to accept or reject any and all bids, or separate portions thereof, and to waive any minor irregularity, technicality or omission if the FSA CPP determines that doing so will serve its best interest or the best interest of the purchasers. A minor irregularity is a variation from the Terms & Conditions of this procurement that does not affect the price of the bid or give the Bidder a substantial advantage over other Bidders and thereby restrict or stifle competition and does not adversely impact the interests of the FSA or the purchasers. At its option, the FSA CPP may allow a Bidder to correct minor irregularities but is under no obligation to do so. In doing so, the FSA CPP may request a Bidder to provide clarifying information or additional materials to correct the irregularity. However, the FSA CPP will not request, and a Bidder may not provide the FSA CPP with additional materials that affect the price of the bid or give the Bidder an advantage or benefit not enjoyed by other Bidders.

The FSA CPP may also reject any bids not submitted in the manner specified in this document.

2.27 CONE OF SILENCE

This Invitation to Bid is subject to the Cone of Silence that begins the date the bid submission opens through the intent to award date as indicated in the Bid Calendar. During this period, all communications regarding this solicitation between FSA and Bidder will cease, except for procedural questions, questions regarding problems incurred in the use of the Bid System, or communications initiated by the FSA CPP. All permitted communications during this period shall be made in writing to the contacts identified in Section 1.01 of this Invitation to Bid.

FLORIDA SHERIFFS ASSOCIATION
Cooperative Purchasing Program
Contract Terms and Conditions

3.0 CONTRACT CONDITIONS

3.01 GENERAL REQUIREMENTS

Once the bid has been awarded, the terms and conditions of this document become the contract between the FSA CPP and the awarded Vendor. The Terms & Conditions apply to all items purchased from this contract.

3.02 STATEMENT OF AUTHORITY

Each person signing the contract warrants that they are duly authorized to do so and binds the respective party to the contract.

3.03 VENDOR CONTACT INFORMATION

The Vendor shall maintain current contact information with FSA CPP at all times for sales and submission of purchase orders, quarterly reports and administrative fee payments. If a change occurs during the contract, the Vendor must notify FSA CPP immediately.

3.04 ADDITIONS OR DELETIONS

FSA CPP reserves the right to add or delete any items from this bid or resulting contract when deemed to be in the best interest of FSA and purchasers, at its discretion. This decision to take action may be based upon and not limited to few or no sales, product recalls and other safety issues, Vendor or manufacturer performance, or the product's lack of relevance.

For items that come to market during the contract term, FSA CPP may authorize qualified and awarded Vendors to offer the new item under the existing contract terms and conditions, if the manufacturer authorizes a Vendor to sell the item. FSA CPP will request awarded Vendors submit pricing and will evaluate the responses prior to authorizing awarded Vendors to offer the new item.

3.05 CONTRACT EXTENSION

Contract Extension

The contract may be extended by mutual agreement for up to two (2) additional years, on a year-to-year basis. FSA CPP reserves the right to execute a contract extension or to allow the contract to fully or partially terminate and readvertise for bids, whichever is in the best interest of FSA.

The Vendor may request price adjustments for contract extensions as provided for herein. If no request is received from the Vendor, the FSA CPP will assume that the Vendor has agreed that the optional term may be exercised without a price adjustment. Any adjustment request received after the execution of an extension may not be considered unless otherwise provided for in this contract.

Month-to-Month Continuation

In the event a new contract is not active at the time of this contract's expiration, this contract's terms and conditions shall extend on a month-to-month basis and shall not constitute an implied extension of the contract. Such a month-to-month continuation shall be upon the compensation and payment provided herein.

FLORIDA SHERIFFS ASSOCIATION

Cooperative Purchasing Program

Contract Terms and Conditions

3.06 PRICE ADJUSTMENT

In addition to the cost-plus-percent pricing adjustments available for the Pursuit, Administrative, and Other Vehicles contract, the Terms & Conditions provide the following options for price adjustments:

- Annual Price Adjustments
- Changes to Manufacturer Production or Design
- Manufacturer Certified Adjustments
- Equitable Adjustments

Price adjustment requests must clearly substantiate a need to increase or decrease the price. Price adjustments will not be considered if Vendors are delinquent on administrative fee payments or have outstanding quarterly reports.

Annual Price Adjustment

The FSA CPP may consider annual price adjustments due to:

- Changes in the Producer Price Index (PPI) as published by the U.S. Department of Labor, Bureau of Labor Statistics (BLS); or
- As a result of changes to national or state standards that require substantial price adjustments.

FSA CPP may consider other documentation related to the change to national or state standards but is not obligated to grant price changes without literature from the manufacturer. The FSA CPP will consider the request and will make a final determination on the change in price.

Changes to Manufacturer Production or Design

Significant changes by the manufacturer to the production of and specification design may initiate a price adjustment request. FSA CPP will consider order dates, production factors, model year, or other conditions, as well as the replacement or complete redesign of items. Vendors must provide documentation from the manufacturer.

Manufacturer Certified Adjustments

Vendors must provide documentation from the manufacturer to FSA CPP that shows the additional costs or price adjustments imposed by the manufacturer and substantiate the need for a related price adjustment for this contract.

Equitable Adjustments

The FSA CPP may make an equitable adjustment to the contract terms or pricing at its discretion.

3.07 CONDITIONS

It is understood and agreed that any item offered or shipped as a result of this contract shall be the most current model offered.

FLORIDA SHERIFFS ASSOCIATION

Cooperative Purchasing Program

Contract Terms and Conditions

3.08 PRODUCTION CUTOFF

Vendors shall notify the FSA CPP in writing no less than sixty (60) calendar days prior to the close of final order date by the manufacturer when the final order date is during the term of the contract. Purchase Orders received by the Vendor ten (10) business days prior to the final order date must be accepted and entered into the order system with the manufacturer. Purchase Orders issued and received after the production cutoff date will be subject to availability. In this case, the Vendor and manufacturer have the discretion whether to choose to provide next year's model at current year's prices until the end of the contract term. If the manufacturer cutoff date is during the term of the contract and will affect the purchaser's ability to obtain the items, FSA CPP may consider substitutions from the same manufacturer.

3.09 FACILITIES

The FSA CPP reserves the right to inspect the Vendor's facilities at any time with prior notice.

3.10 PURSUIT RATED VEHICLES & MOTORCYCLES

Vehicles in this category have been reviewed by one or more of the nationally recognized authorities on Police Vehicle Testing Program/Evaluation. These evaluations are not designed to recommend a particular product, but to serve as a resource for vehicles which are currently being offered for law enforcement service. To see the full detailed report, click or copy the links below. At the time of the bid there were two nationally recognized authorities:

[State of Michigan, Vehicle Test Team of the Michigan State Police \(MSP\) Precision Driving Unit](#)

[Los Angeles County Sheriff's Department Law Enforcement Vehicle Test and Evaluation Program Vehicles:](#)

3.11 SPECIAL SERVICE VEHICLES

Vehicles in this category have been reviewed by one or more of the nationally recognized authorities on pursuit vehicle testing program/evaluation. These vehicles are labeled as Special Service Vehicle (SSV) and often used in public safety applications and other areas of government. Refer to manufacturers published information for detailed information regarding these vehicles.

3.12 CAB AND CHASSIS PURCHASES

Vendors performing upfitting of cab and chassis should be licensed and certified to perform such work. Vendors are responsible for tag and title work if the chassis is completed by the Vendor or the Vendor's contracted third-party supplier. The requirements of Florida Statute 319.21 related to the manufacturer statement of origin apply to cab and chassis purchases.

Cab and chassis may be purchased from the Vendor without any required additional upfitting by the Vendor. Vendors are not responsible for tag and title if an incomplete chassis is requested and sold to the purchaser.

3.13 FACTORY-INSTALLED OPTIONS

All options specified as factory-installed are to be installed on the item at the primary site of assembly and are to

FLORIDA SHERIFFS ASSOCIATION

Cooperative Purchasing Program

Contract Terms and Conditions

be the manufacturer's standard assembly-line product. Aftermarket and vendor-installed equipment will not be accepted as factory-installed. Vendors found supplying aftermarket or vendor-installed equipment where factory-installed are specified shall be required to retrieve all delivered items and supply new items meeting the specifications.

All factory-ordered options are to be original equipment manufacturer (OEM) and installed at the primary site of assembly unless otherwise noted by the Vendor and acknowledged in writing by the purchaser. Verbal agreements will not be recognized.

3.14 VENDOR-INSTALLED OPTIONS

All vendor-installed accessories, equipment, or options shall be installed according to the manufacturer's specifications. All vendor-installed options must be manufactured by an established manufacturer of the product provided. Vendors are required to disclose make and model of product being offered, design, and model must be approved by the purchaser prior to installation. Prior to any purchase, the Vendor must also disclose the warranty of any accessory, equipment or option that is less than or exceeds the factory or equipment warranty coverage. Any Vendor that violates this provision will be considered in default of the contract. FSA CPP may terminate the contract in accordance with these terms & conditions.

3.15 NON-SCHEDULED OPTIONS

A non-scheduled option is an option not listed on the FSA CPP published award. Vendors may provide non-scheduled options at less than MSRP or the Published List Price. Non-scheduled options should be identified and listed as a separate line item with the price and discount on the purchase order. Non-scheduled options are covered under these terms and conditions.

3.16 FORCE MAJEURE

A Vendor shall not be penalized for a delay resulting from the Vendor's failure to comply with delivery requirements if neither the fault nor the negligence of the Vendor or its employees contributed to the delay and the delay is due directly to acts of God, wars, acts of public enemies, strikes, fires, floods, or other similar cause wholly beyond the Vendor's control, or for any of the foregoing that third party suppliers if no alternate source of supply is available to the Vendor.

3.17 PURCHASE ORDERS

To initiate a purchase, a purchase order must be issued to the Vendor, which includes:

- FSA CPP contract title and number;
- FSA CPP item number, and the make and model or item description; and
- Purchaser name, phone number and email address.

The Vendor's acceptance of a purchaser's order will indicate that the Vendor agrees to deliver an awarded item that will be fully compatible with all of its options. Production schedules and delivery dates should be discussed at the time the quote is provided to the purchaser, or if no quote is provided, when the purchase order is delivered to the Vendor. Vendor shall place the order with the manufacturer within 10 business days of receipt of the purchase order. The Vendor shall assure that all orders are placed in full compliance with the specifications and the terms and conditions of the contract and the purchase order. Any changes that are required to bring an item into compliance with the various options due to an incorrect order will be accomplished at the Vendor's expense.

FLORIDA SHERIFFS ASSOCIATION

Cooperative Purchasing Program

Contract Terms and Conditions

A Confirmation of Order form shall be completed by the Vendor and provided to the purchaser and FSA CPP fifteen (15) calendar days from receipt of purchase order without request by the purchaser. Any additional information needed to complete this form should be obtained by the Vendor from the purchaser.

While it is recommended that an agency purchase from the zone which is closest to their location, it is not mandatory to do so. If the purchaser determines that a Vendor in another zone can better serve the purchaser's needs, the purchaser may order from a Vendor in another zone. Vendors that provide awarded items outside of an awarded zone may upon mutual agreement between the Vendor and the purchaser charge a delivery fee.

If a Vendor receives a purchase order for an item for which they were not awarded, the Vendor must notify the purchaser and return the purchase order to the purchaser within three (3) business days.

The Vendor must submit electronic copies of Purchase Orders within fifteen (15) calendar days of the Purchase Order issue date. Emails shall be sent to coop@flsheriffs.org. Purchase orders received by the Vendor after this deadline must be submitted to FSA CPP as soon as possible with the date received by the Vendor and cause for the delay. Purchase Orders should contain the following required information:

- Purchaser name,
- Purchase order number,
- Purchase order issue date,
- FSA CPP contract title and number,
- Item number,
- Item make and model, or item description,
- Item price,
- Options by item, and
- Estimated delivery date.

Purchase orders vary in format and information provided. If a purchase order does not include the required information, the Vendor must submit supplemental documentation to FSA CPP at the same time the purchase order is due. Such information may be in bid quotes, equipment proposals, confirmation of orders, or other documents. If a purchaser does not use purchase orders, written communication from the purchaser to the Vendor will be provided to FSA CPP.

3.18 REGISTRATION, TAG, AND TITLE

Title items shall be the responsibility of the Vendor. If the purchaser is a government agency, the purchaser has the right to choose to register and title the item. Costs of registration, tag and title shall not exceed the statutory rates. FSA administrative fee does not apply to the cost of registration, tag and title.

3.19 DELIVERY

Vendors are to inspect the item to confirm the item meets or exceeds the FSA CPP Base Specification, manufacturer specification, and purchase order. Deliveries not complying with these requirements may be rejected and will have to be redelivered at Vendor's expense.

Delivery shall be within the normal working hours of the user, Monday through Friday, excluding holidays. Delivery schedules shall be agreed to by the purchaser and the Vendor. Vendor shall notify the purchaser no less than twenty-four (24) hours prior to delivery of the time and location, which shall reflect the mutually agreed upon

FLORIDA SHERIFFS ASSOCIATION

Cooperative Purchasing Program

Contract Terms and Conditions

delivery details. The Vendor shall be responsible for delivering items that are properly serviced, clean and in first class operating condition. Items shall be delivered with each of the following documents completed or included:

1. Copy of the Purchase Order.
2. Copy of the FSA CPP Base Specification.
3. Copy of manufacturer's Invoice, price sheet, build sheet or other documentation that verifies what components are included on the item being delivered
4. Copy of the pre-delivery service report
5. Registration warranty certification
6. Owner's manual
7. Registration, tag and title or an application for the registration, as applicable

All items with fuel tanks of thirty-five (35) gallons or less must contain no less than one quarter (1/4) tank of fuel as indicated by the fuel gauge at the time of delivery. For items that have more than thirty-five (35) gallons, a minimum of one eighth (1/8) of a tank of fuel must be provided. All electric vehicles must be delivered with a minimum charge level of 10 percent. The purchaser has the option to reject a vehicle with more than 350 odometer miles or may deduct \$0.51 cents per mile in excess of 350 miles from the invoice, unless distance above 350 miles was previously approved by the purchaser. Deliveries of less than 350 miles may be accomplished by driving the vehicle. Any delivery accomplished by driving the vehicle must be supervised and the driver must comply with manufacturer's break-in requirements and all applicable traffic laws. Any delivery accomplished by driving a pursuit-rated vehicle must use an "OUT OF SERVICE" cover on light bars. Deliveries in excess of 350 miles shall be made by transport, or otherwise approved by the purchaser, however, this requirement shall not apply to incomplete chassis.

Items with hour meters must be delivered with fewer than five (5) hours on the hour meter or may be rejected by the purchaser. The purchaser may choose to negotiate a lower purchase price when the item exceeds five (5) hours.

When items require service or adjustments upon delivery, the Vendor shall either remedy the defect, or be responsible for reimbursing the manufacturer's local authorized representative or other service provider to remedy the defect. Such service or adjustments shall be initiated by the Vendor within 48 hours after notification by a purchaser, not to include weekends and holidays. Delivery will not be considered complete until all services or adjustments are satisfactory, and the item is redelivered or repaired. The cost of any transportation required to address the defect shall be the responsibility of the Vendor until the items are satisfactory and accepted by the purchaser.

3.20 INSPECTION AND ACCEPTANCE

Final acceptance shall be given only after the purchaser inspects or confirms the item meets contract specifications. Delivery of an item to a purchaser does not constitute acceptance for the purpose of payment. Inspection and acceptance will be at the purchaser's destination unless otherwise previously agreed upon location was provided in the purchase order. Should the delivered items differ in any respect from the Base Item specifications, payment can be withheld until such time as the Vendor completes the necessary corrective action.

3.21 INVOICING AND PAYMENTS

Invoicing and payments shall be the responsibility of the Vendor and purchaser placing orders using this contract. Vendors must invoice each purchaser independently. The Vendor shall be paid upon submission of invoices to the purchaser after satisfactory delivery and acceptance of the items. While the Local Government Prompt Payment

FLORIDA SHERIFFS ASSOCIATION Cooperative Purchasing Program Contract Terms and Conditions

Act applies to ensure timely payment of Vendor invoices, the FSA CPP encourages purchasers to make payment within 30 days of acceptance of the item. The Local Government Prompt Payment Act is defined in Sections 218.70–218.79 of Florida Statutes.

3.22 WARRANTY

All warranties shall begin at the time of delivery and final acceptance by the purchaser. The purchaser’s warranty should not be active for incomplete items and items delivered to a third-party supplier before final delivery.

3.23 QUARTERLY REPORTS

Quarterly reports are the contractual responsibility of each Vendor. Quarterly reports must be completed and submitted electronically. All quarterly reports shall be sent to reports@flsheriffs.org. The quarterly report template shall be submitted using an Excel workbook provided by FSA CPP. Quarterly reports which do not adhere to the required format or are not complete of all purchase orders received and/or deliveries made during the quarter will be returned to the reporting Vendor for correction.

Quarterly reports are due no later than the 15th day of the month following the end of the quarter. Quarterly reports shall follow the schedule below for the duration of the contract. If a contract extension is executed, the quarterly reports will maintain the same schedule for future reporting periods.

Contract Year: October 1, 2022 – September 30, 2023

Year 1 Quarter 1:	October 1 – December 31	Q1 Report Due:	January 15
Year 1 Quarter 2:	January 1 – March 31	Q2 Report Due:	April 15
Year 1 Quarter 3:	April 1 – June 30	Q3 Report Due:	July 15
Year 1 Quarter 4:	July 1 – September 30	Q4 Report Due:	October 15

Quarterly reports must be submitted even if there are no sales or no deliveries in a quarter. If a Vendor has no sales within a quarter, the Vendor shall indicate “No sales this quarter” on the top row of the sales worksheet. If the Vendor has no deliveries in a given quarter, the Vendor shall indicate “No deliveries this quarter” on the top row of the delivery worksheet.

FSA CPP reserves the right to modify the procedure for submitting quarterly reports during the term of the contract. Such a change shall not materially modify the substance of the information to be reported but may change the method by which future quarterly reports are to be submitted. In the event of such a change, FSA CPP will provide written notice to all Vendors of the method by which future quarterly reports are to be submitted.

3.24 ADMINISTRATIVE FEE

The FSA CPP charges three quarters of one percent (.0075) to procure, process and administer the contract. The administrative fees are the contractual responsibility of each awarded Vendor.

After receipt of payment from contract purchases, the Vendor shall remit all administrative fees to the FSA CPP no later than 15 calendar days after the end of each quarter. All fees payable to the FSA CPP during any given quarter will be accompanied and supported by a quarterly report.

FLORIDA SHERIFFS ASSOCIATION
Cooperative Purchasing Program
Contract Terms and Conditions

The administrative fee will remain payable to FSA CPP and no relief from payment of the administrative fee, nor any additional charge to recoup the administrative fee, will be permitted if a Vendor fails to incorporate the administrative fee in its bid pricing. The administrative fee should never be listed as a separate line item on any purchase order or invoice.

The administrative fee is based on the total purchase order amount of new items. This fee excludes any value given to purchasers for trade-ins. Trade-ins, extended warranties and other exchanges will not reduce or impact the fee calculation.

The ACH form for electronic payment or wiring of funds is included in Appendix C. It is the preference of FSA CPP that all payments be electronically paid and submitted. If ACH is not available, checks for the administrative fee can be sent to:

Florida Sheriffs Association
 Cooperative Purchasing Program
 2617 Mahan Drive
 Tallahassee, FL 32308

3.25 LIQUIDATED DAMAGES

The Vendor warrants that the item supplied to the purchaser shall conform in all respects to the standards set forth and the failure to comply with this condition will be considered as a breach of contract. Any liquidated damages levied because of inadequacies or failures to comply with these requirements shall be borne solely by the Vendor responsible for same.

Failure to submit the administrative fee with accompanying quarterly reports to FSA CPP within 15 calendar days following the end of each quarter may result in the imposition of liquidated damages. Vendors failing to submit administrative fees and/or quarterly reports will incur liquidated damages in the amount of \$25 for each calendar day that fees and reports are past due, beginning on the 16th day following the end of the quarter.

If a civil action is initiated by the FSA to recover administrative fees or liquidated damages as set forth in this section, the prevailing party shall be entitled to its reasonable attorneys’ fees and costs incurred in the litigation. The venue shall lie in the Circuit Court for the Second Judicial Circuit in and for Leon County, Florida.

When quarterly reports are late, liquidated damages are to be included in Vendor’s Quarterly Report and administrative fee submission. Liquidated damages that remain unpaid beyond 45 calendar days can result in FSA CPP, at its sole discretion, implementing contract compliance actions, including but not limited to, suspension, limited participation by specifications or zones, disqualification from future solicitations, or termination for cause pursuant to the Terms & Conditions.

Schedule of Liquidated Damages

Failure to submit quarterly report on time	\$25 per calendar day
Failure to submit administrative fee on time	\$25 per calendar day
Failure to report a Purchase Order to FSA CPP within 15 calendar days of the purchase order issue date	\$100 per Purchase Order
Failure to Report Sales	.0075 of the sales price plus 1.5% each month following the delivery date.

FLORIDA SHERIFFS ASSOCIATION
Cooperative Purchasing Program
Contract Terms and Conditions

Vendor agrees and acknowledges that its failure to take any of the actions specified in the above schedule will result in liquidated damages to this contract. Vendor agrees and acknowledges that these liquidated damages are not intended to be and do not constitute a penalty and that these amounts are reasonably calculated to compensate the FSA for the damages that it will incur as a result of the Vendor's failure to take the specified actions.

FLORIDA SHERIFFS ASSOCIATION Cooperative Purchasing Program Contract Terms and Conditions

Appendix A: Zone Map

FSA CONTRACT ZONE MAP

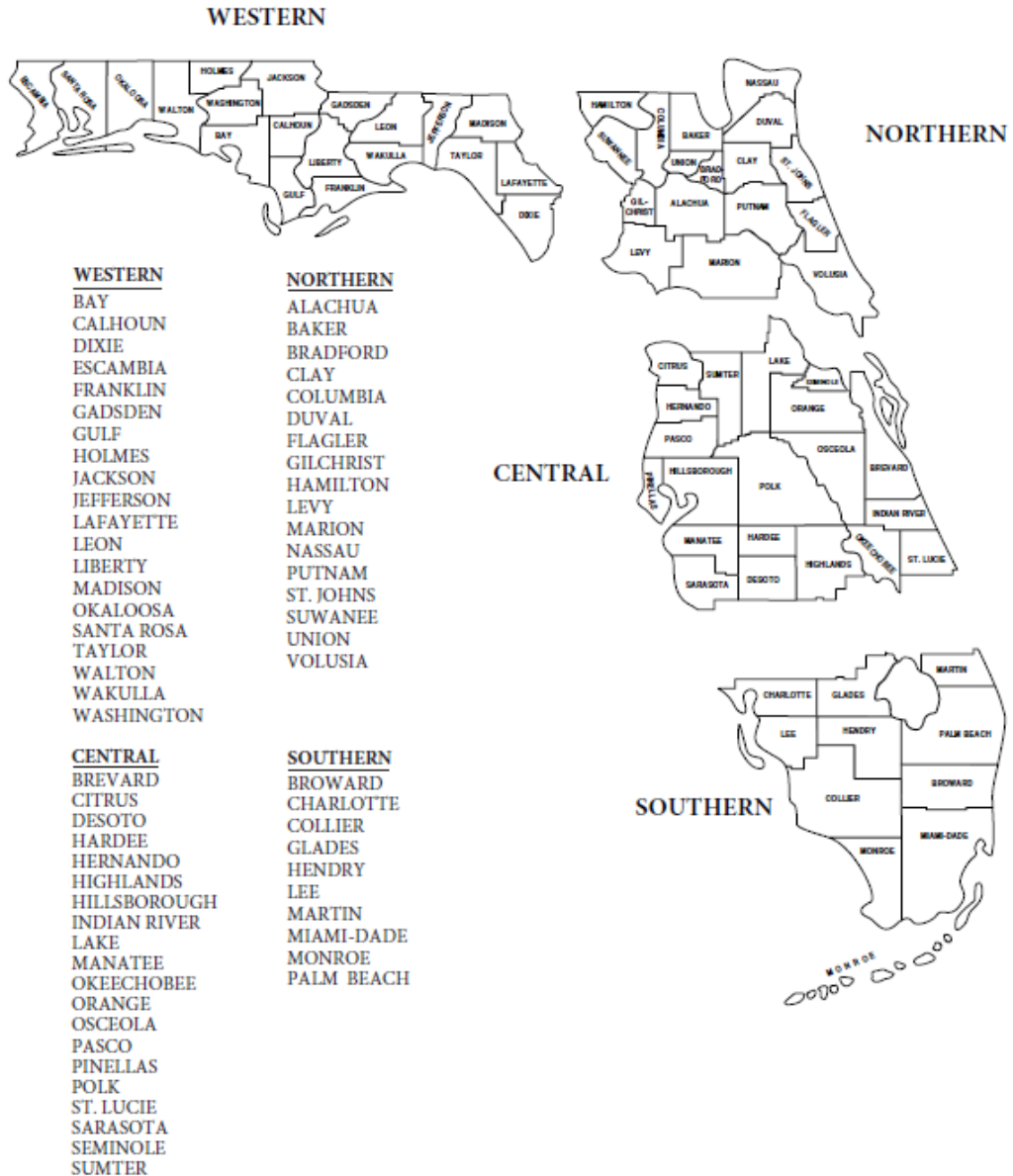

FLORIDA SHERIFFS ASSOCIATION
Cooperative Purchasing Program
 Contract Terms and Conditions

Appendix B. Bid Calendar

FSA23-VEL31.0	
Bid Calendar Task	Date
Invitation to Bid Announcement (ITB)	5/1/2023 & 5/15/2023
Voluntary Interested Bidder Workshop	6/13/2023
New Item Specification Requests Due	6/23/2023
Pre Bid Meeting	7/11/2023
Request for Clarifications Due to FSA	7/18/2023
FSA VendorLink Bidder Training	7/24/2023
Bid System Open	7/25/2023
Cone of Silence	7/25/2023 - 9/11/2023
Bid Submissions Due	8/30/2023
Public Bid Opening	9/1/2023
Bid Tabulations Posted	9/1/2023
Bid Evaluation	9/5/2023 - 9/8/2023
Intent To Award	9/11/2023
Final Award & Effective Date of New Contract	10/1/2023

FSA23-VEH21.0	
Bid Calendar Task	Date
Invitation to Bid Announcement (ITB)	5/1/2023 & 5/15/2023
Voluntary Interested Bidder Workshop	6/14/2023
New Item Specification Requests Due	6/23/2023
Pre Bid Meeting	7/12/2023
Request for Clarifications Due to FSA	7/18/2023
FSA VendorLink Bidder Training	7/24/2023
Bid System Open	7/25/2023
Cone of Silence	7/25/2023 - 9/11/2023
Bid Submissions Due	8/30/2023
Public Bid Opening	9/1/2023
Bid Tabulations Posted	9/1/2023
Bid Evaluation	9/5/2023 - 9/8/2023
Intent To Award	9/11/2023
Final Award & Effective Date of New Contract	10/1/2023

FLORIDA SHERIFFS ASSOCIATION
Cooperative Purchasing Program
 Contract Terms and Conditions

FSA23-EQU21.0	
Bid Calendar Task	Date
Invitation to Bid Announcement (ITB)	5/1/2023 & 5/15/2023
Voluntary Interested Bidder Workshop	6/7&8/2023
New Item Specification Requests Due	6/23/2023
Pre Bid Meeting	7/13/2023
Request for Clarifications Due to FSA	7/18/2023
FSA VendorLink Bidder Training	7/24/2023
Bid System Open	7/25/2023
Cone of Silence	7/25/2023 - 9/11/2023
Bid Submissions Due	8/30/2023
Public Bid Opening	9/1/2023
Bid Tabulations Posted	9/1/2023
Bid Evaluation	9/5/2023 - 9/8/2023
Intent To Award	9/11/2023
Final Award & Effective Date of New Contract	10/1/2023

FLORIDA SHERIFFS ASSOCIATION
Cooperative Purchasing Program
Contract Terms and Conditions

Appendix C: ACH Payments



Protecting, Leading & Uniting...since 1893

FLORIDA SHERIFFS ASSOCIATION

2617 Mahan Drive, Tallahassee, Florida 32308
P.O. Box 12519 • Tallahassee, Florida 32317-2519

p: (850) 877-2165

f: (850) 878-8665

www.flsheriffs.org



TO: All Customers of the Florida Sheriffs Association

SUBJECT: Florida Sheriffs Association is going paperless!

Our association is pleased to announce the implementation of accepting electronic payments from customers. If your agency or company is able to pay via ACH, please consider adding the Florida Sheriffs Association to your list of vendors paid via electronic payment.

Florida Sheriffs Association's Banking Information is as follows:

Checking Account

Capital City Bank

Routing Number: 063100688

Account Number: 0010867001

Please email any payment remittance information to accounting@flsheriffs.org.

If you choose to make ACH payments to the association, there is no additional charge. However, the information above can be used to pay with a wire transfer. If you choose to pay via wire, there is a charge of \$25 per wire that you will need to add to your payment.

If you have any questions at all, please contact Trish Eldridge at teldridge@flsheriffs.org or call (850) 559-5668.

Sincerely,

Trish Eldridge

Director of Accounting and Finance
Florida Sheriffs Association

FLORIDA SHERIFFS ASSOCIATION
Cooperative Purchasing Program
Contract Terms and Conditions

Appendix D: Federal Clauses

Applicability of Third-Party Contract Provisions*

(Excluding micro-purchases, except Davis-Bacon requirements apply to construction contracts exceeding \$2,000.)

In addition to other provisions negotiated with purchasers placing federally funded purchase orders, Vendors must comply with the following provisions upon award of a federally funded purchase order:

PROVISION	Professional Services/A&E	Operations/ Management	Construction	Materials & Supplies
Equal Employment Opportunity			All	
Davis-Bacon Act			>\$2,000	
Copeland "Anti-Kickback" Act			>\$2,000	
Contract Work Hours and Safety Standards Act	>\$100,000	>\$100,000	>\$100,000	>\$100,000
Rights to Inventions Made Under a Contract or Agreement	If the purchase order involves performance of experimental, developmental or research work	If the purchase order involves performance of experimental, developmental or research work	If the purchase order involves performance of experimental, developmental or research work	If the purchase order involves performance of experimental, developmental or research work
Clean Air Act	>\$150,000	>\$150,000	>\$150,000	>\$150,000
Federal Water Pollution Control Act	>\$150,000	>\$150,000	>\$150,000	>\$150,000
Debarment and Suspension	All	All	All	All
Byrd Anti-Lobbying Amendment	>\$100,000	>\$100,000	>\$100,000	>\$100,000
Procurement of Recovered Materials	All	All	All	All
Prohibition on Certain Telecommunications and Video Surveillance Services or Equipment	All	All	All	All
Domestic Preferences for Procurements	All	All	All	All

*References to the code of regulations (CFR) or United States Code (USC) were accurate at the time of publication. It is the responsibility of the Bidder to ensure compliance is met of the referenced state and federal laws within the published rules.

EQUAL EMPLOYMENT OPPORTUNITY: Except as otherwise provided under 41 CFR Part 60, all contracts that meet the definition of "federally assisted construction contract" in 41 CFR Part 60-1.3 must include the equal opportunity clause provided under 41 CFR 60-1.4(b), in accordance with Executive Order 11246, "Equal Employment Opportunity" (30 FR 12319, 12935, 3 CFR Part, 1964-1965 Comp., p. 339), as amended by Executive Order 11375, "Amending Executive Order 11246 Relating to Equal Employment Opportunity," and implementing regulations at 41 CFR part 60, "Office of Federal Contract Compliance Programs, Equal Employment Opportunity, Department of Labor." The clause set forth in 41 CFR 60-1.4(b) is incorporated herein by reference. Vendor must comply with this clause and include this clause in all lower-tier federal assisted construction contracts.

FLORIDA SHERIFFS ASSOCIATION
Cooperative Purchasing Program
Contract Terms and Conditions

DAVIS-BACON ACT, as amended (40 U.S.C. 3141-3148): When required by Federal program legislation, all prime construction contracts in excess of \$2,000 awarded by non-Federal entities must include a provision for compliance with the Davis-Bacon Act (40 U.S.C. 3141-3144, and 3146-3148) as supplemented by Department of Labor regulations (29 CFR Part 5, "Labor Standards Provisions Applicable to Contracts Covering Federally Financed and Assisted Construction"). In accordance with the statute, contractors must be required to pay wages to laborers and mechanics at a rate not less than the prevailing wages specified in a wage determination made by the Secretary of Labor. In addition, contractors must be required to pay wages not less than once a week. The non-Federal entity must place a copy of the current prevailing wage determination issued by the Department of Labor in each solicitation. The decision to award a contract or subcontract must be conditioned upon the acceptance of the wage determination. The non-Federal entity must report all suspected or reported violations to the Federal awarding agency. The contracts must also include a provision for compliance with the Copeland "Anti-Kickback" Act (40 U.S.C. 3145), as supplemented by Department of Labor regulations (29 CFR Part 3, "Contractors and Subcontractors on Public Building or Public Work Financed in Whole or in Part by Loans or Grants from the United States"). The Act provides that each contractor or subrecipient must be prohibited from inducing, by any means, any person employed in the construction, completion, or repair of public work, to give up any part of the compensation to which he or she is otherwise entitled. The non-Federal entity must report all suspected or reported violations to the Federal awarding agency. Vendors performing construction must comply with all applicable provisions of the Davis-Bacon Act and include this clause in all lower-tier subcontracts for construction.

CONTRACT WORK HOURS AND SAFETY STANDARDS ACT (40 U.S.C., chapter 37): Vendor shall comply with Sections 102 and 107 of the Contract Work Hours and Safety Standards Act (40 U.S.C., chapter 37), as supplemented by Department of Labor regulations (29 CFR part 5).

(a) Overtime requirements. Neither Vendor nor any contractor or subcontractor contracting for any part of the purchase order work which may require or involve the employment of laborers or mechanics shall require or permit any such laborer or mechanic in any workweek in which he or she is employed on such work to work in excess of forty hours in such workweek unless such laborer or mechanic receives compensation at a rate not less than one and one-half times the basic rate of pay for all hours worked in excess of forty hours in such workweek.

(b) Violation; liability for unpaid wages; liquidated damages. In the event of any violation of the clause set forth in Paragraph 15(a), Vendor and any subcontractor responsible therefor shall be liable for the unpaid wages. In addition, Vendor or such subcontractor shall be liable to the United States (in the case of work done under the Contract for the District of Columbia or a territory, to such District or to such territory), for liquidated damages. Such liquidated damages shall be computed with respect to each individual laborer or mechanic, including watchmen and guards, employed in violation of the clause set forth in Paragraph 15(a), in the sum of \$29 for each calendar day on which such individual was required or permitted to work in excess of the standard workweek of forty hours without payment of the overtime wages required by the clause set forth in Paragraph 15(a) of this section.

(c) Withholding for unpaid wages and liquidated damages. Purchaser shall upon its own action or upon written request of an authorized representative of the Department of Labor withhold or cause to be withheld, from any moneys payable on account of work performed by Vendor or a subcontractor under the purchase order or any other Federal contract with Purchaser, or any other federally-assisted contract subject to the Contract Work Hours and Safety Standards Act, which is held by Purchaser, such sums as may be determined to be necessary to satisfy any liabilities of Vendor or its subcontractor for unpaid wages and liquidated damages as provided in the clause set forth in Paragraph (a).

(d) Subcontracts. Vendor shall insert in any subcontracts over \$100,000 for construction and other purposes that involve the employment of mechanics or laborers, the clauses set forth in Paragraphs (a) through (d) and also a clause requiring the subcontractors to include these clauses in any lower-tier subcontracts.

RIGHTS TO INVENTIONS MADE UNDER A CONTRACT OR AGREEMENT: If the Federal award meets the definition of "funding agreement" under 37 CFR § 401.2 (a) and the recipient or subrecipient wishes to enter into a contract with

FLORIDA SHERIFFS ASSOCIATION

Cooperative Purchasing Program

Contract Terms and Conditions

a small business firm or nonprofit organization regarding the substitution of parties, assignment or performance of experimental, developmental, or research work under that "funding agreement," the recipient or subrecipient must comply with the requirements of 37 CFR Part 401, "Rights to Inventions Made by Nonprofit Organizations and Small Business Firms Under Government Grants, Contracts and Cooperative Agreements," and any implementing regulations issued by the awarding agency. Vendor shall comply with these requirements when performing a purchase order involving experimental, developmental or research work and flowdown this clause to lower-tier subcontractors performing such work.

CLEAN AIR ACT (42 U.S.C. 7401 *et seq.*) and the FEDERAL WATER POLLUTION CONTROL ACT (33 U.S.C. 1251 *et seq.*), as amended: Vendor agrees to comply with all applicable standards, orders or regulations issued pursuant to the Clean Air Act (42 U.S.C. 7401 *et seq.*) and the Federal Water Pollution Control Act as amended (33 U.S.C. 1251 *et seq.*). Violations shall be reported to the Federal awarding agency and the Regional Office of the Environmental Protection Agency (EPA). Vendor shall comply with the requirements of Clean Air Act and the Federal Water Pollution Control Act and include this clause in all lower-tier subcontracts with a value over \$150,000.

DEBARMENT AND SUSPENSION (E.O.s 12549 and 12689): By accepting or performing this purchase order, Vendor certifies that it is not identified in the Exclusions area of the System for Award Management as being currently debarred, suspended, proposed for debarment, or otherwise excluded ("SAM Exclusion"). Vendor shall obtain similar certifications from its lower-tier subcontractors for each subcontract in excess of \$25,000 and Vendor shall not award lower-tier subcontracts in excess of \$25,000 to an entity subject to a SAM Exclusion.

LOBBYING RESTRICTIONS (31 U.S.C. 1352): By accepting or performing this purchase order, Vendor certifies that it will not and has not used Federal appropriated funds to pay any person or organization for influencing or attempting to influence an officer or employee of any agency, a member of Congress, officer or employee of Congress, or an employee of a member of Congress in connection with obtaining any Federal contract, grant or any other award covered by 31 U.S.C. 1352. Vendor shall also disclose to Purchaser any lobbying with non-Federal funds that takes place in connection with obtaining any Federal award or contract. Vendor shall flow down this clause and require this certification for lower-tier subcontractors with a subcontract of \$100,000 or more. Vendor shall provide its disclosure and all disclosures received from lower-tier subcontractors to Purchaser.

PROCUREMENT OF RECOVERED MATERIALS: A non-Federal entity that is a state agency or agency of a political subdivision of a state and its contractors must comply with section 6002 of the Solid Waste Disposal Act, as amended by the Resource Conservation and Recovery Act. The requirements of Section 6002 include procuring only items designated in guidelines of the Environmental Protection Agency (EPA) at 40 CFR part 247 that contain the highest percentage of recovered materials practicable, consistent with maintaining a satisfactory level of competition, where the purchase price of the item exceeds \$10,000 or the value of the quantity acquired during the preceding fiscal year exceeded \$10,000; procuring solid waste management services in a manner that maximizes energy and resource recovery; and establishing an affirmative procurement program for procurement of recovered materials identified in the EPA guidelines. Vendor shall comply with this clause and include this clause in all lower-tier subcontracts.

PROHIBITION ON CERTAIN TELECOMMUNICATIONS AND VIDEO SURVEILLANCE SERVICES OR EQUIPMENT:

(a) Recipients and subrecipients are prohibited from obligating or expending loan or grant funds to:

- (1) Procure or obtain;
- (2) Extend or renew a contract to procure or obtain; or
- (3) Enter into a contract (or extend or renew a contract) to procure or obtain equipment, services, or systems that uses covered telecommunications equipment or services as a substantial or essential component of any system, or as critical technology as part of any system. As described in Public Law 115-232, section 889, covered telecommunications equipment is telecommunications equipment produced by Huawei Technologies Company or ZTE Corporation (or any subsidiary or affiliate of such entities).

FLORIDA SHERIFFS ASSOCIATION
Cooperative Purchasing Program
Contract Terms and Conditions

(i) For the purpose of public safety, security of government facilities, physical security surveillance of critical infrastructure, and other national security purposes, video surveillance and telecommunications equipment produced by Hytera Communications Corporation, Hangzhou Hikvision Digital Technology Company, or Dahua Technology Company (or any subsidiary or affiliate of such entities).

(ii) Telecommunications or video surveillance services provided by such entities or using such equipment.

(iii) Telecommunications or video surveillance equipment or services produced or provided by an entity that the Secretary of Defense, in consultation with the Director of the National Intelligence or the Director of the Federal Bureau of Investigation, reasonably believes to be an entity owned or controlled by, or otherwise connected to, the government of a covered foreign country.

(b) In implementing the prohibition under Public Law 115-232, section 889, subsection (f), paragraph (1), heads of executive agencies administering loan, grant, or subsidy programs shall prioritize available funding and technical support to assist affected businesses, institutions and organizations as is reasonably necessary for those affected entities to transition from covered communications equipment and services, to procure replacement equipment and services, and to ensure that communications service to users and customers is sustained.

(c) See Public Law 115-232, section 889 for additional information.

DOMESTIC PREFERENCES FOR PROCUREMENTS:

(a) As appropriate and to the extent consistent with law, the non-Federal entity should, to the greatest extent practicable under a Federal award, provide a preference for the purchase, acquisition, or use of goods, products, or materials produced in the United States (including but not limited to iron, aluminum, steel, cement, and other manufactured products). Vendor agrees to comply with the requirements of this clause and include the requirements of this clause in all subawards including all contracts and purchase orders for work or products under this award.

(b) For purposes of this section:

(1) "Produced in the United States" means, for iron and steel products, that all manufacturing processes, from the initial melting stage through the application of coatings, occurred in the United States.

(2) "Manufactured products" means items and construction materials composed in whole or in part of non-ferrous metals such as aluminum; plastics and polymer-based products such as polyvinyl chloride pipe; aggregates such as concrete; glass, including optical fiber; and lumber.



FSA23-VEH21.0: Heavy Trucks and Buses Item Group Descriptions

Item Groups Summary

All bid items shall be built to manufacturer base specifications for the item or model number indicated and shall include all standard manufacturer equipment unless otherwise specified. If not already included in manufacturer base specifications, all vehicles shall include air conditioning. When requested by the purchaser, vendors must submit detailed specifications for the item and options offered. Vendors are responsible for providing a chassis (including front axle, rear axle, wheels, and tires) of sufficient GVWR to safely accommodate all options selected by the purchaser. In all areas of these specifications, bidders must comply with current Federal Motor Vehicle Safety Standards (FMVSS, where applicable), and National Highway Traffic Safety Administration (NHTSA) standards.

Buses

- Buses Electric: 19 to 20 Passenger Capacity Range, Van-Type Cutaway Chassis
- Buses Electric: 20 to 52 Passenger Capacity Range, Conventional-Type Chassis
- Buses Electric: 44 To 80 Passenger Capacity Range, Commercial-Type Chassis
- Buses: 14 to 25 Passenger Capacity Range, Van-Type Cutaway Chassis
- Buses: 20 to 52 Passenger Capacity Range, Conventional Truck-Type Cutaway Chassis
- Buses: 33 to 54 Passenger Capacity Range, Commercial-Type, Rear Engine Chassis
- Buses: 36 to 52 Passenger Capacity Range, Commercial-Type, Front Engine Chassis

Cab and Chassis Trucks

- Cab and Chassis Trucks Electric: 54,000 lbs. GVWR 4x6 Semi Tractor
- Cab and Chassis Trucks Electric: Tilt Cab 26,000 lbs. GVWR (DRW) 4x2
- Cab and Chassis Trucks Electric: Conventional Cab 33,000 lbs. GVWR (DRW) 4x2*
- Cab and Chassis Trucks: 17,500 lbs. GVWR (DRW) 4x2
- Cab and Chassis Trucks: 17,500 lbs. GVWR (DRW) 4x4
- Cab and Chassis Trucks: 25,500 lbs. GVWR (DRW) 4x2
- Cab and Chassis Trucks: 30,000 lbs. GVWR (DRW) 4x2
- Cab and Chassis Trucks: 52,000 lbs. GVWR Semi Tractor 4x6
- Cab and Chassis Trucks: 52,000 lbs. GVWR Truck 4x6
- Cab and Chassis: Tilt Cab (DRW) 4x2
- Mobile Command Unit/Critical Response Unit
- Refuse Truck Electric: 60,000 lbs. GVWR 4x6 (cab and chassis only)
- Refuse Truck: 60,000 lbs. GVWR 4x6 (cab and chassis only)
- Refuse Truck: Compact 9.5 Cubic Yds. Self-Loading Refuse Truck
- Tactical Armored Vehicles
- Terminal Tractor*



**FSA23-VEH21.0: Heavy Trucks and Buses
Item Group Descriptions**

** Indicates new item group*



**FSA23-VEH21.0: Heavy Trucks and Buses
Item Group Descriptions**

Buses Electric: 19 to 20 Passenger Capacity Range, Van-Type Cutaway Chassis

FSA Item Group Description

- Electric Motor: 160 kW, 215 hp minimum
 - Batteries: 68 kW minimum
 - GVWR: 14,500 lbs. (approximate, sized to meet passenger capacity)
 - Passenger Seating: Seating for 19 passengers minimum
-



**FSA23-VEH21.0: Heavy Trucks and Buses
Item Group Descriptions**

Buses Electric: 20 to 52 Passenger Capacity Range, Conventional-Type Chassis

FSA Item Group Description

- Electric Motor: 230 kW, 315 hp minimum
 - Batteries: 155 kW battery capacity minimum
 - GVWR: 23,500 lbs. (approximate, sized to meet passenger capacity)
 - Passenger Seating: Seating for 20 passengers minimum
-



**FSA23-VEH21.0: Heavy Trucks and Buses
Item Group Descriptions**

Buses Electric: 44 To 80 Passenger Capacity Range, Commercial-Type Chassis

FSA Item Group Description

- Electric Motor: 230 kW, 315 hp
 - Batteries: 155 kW battery capacity (approximate)
 - GVWR: 36,000 lbs. (approximate, sized to meet passenger capacity)
 - Passenger Seating: Seating for 44 passengers minimum
-



**FSA23-VEH21.0: Heavy Trucks and Buses
Item Group Descriptions**

Buses: 14 to 25 Passenger Capacity Range, Van-Type Cutaway Chassis

FSA Item Group Description

- Engine: Gas
 - Transmission: Automatic
 - GVWR: 10,350 lbs. (approximate, sized to meet passenger capacity)
 - Passenger Seating: Seating for 14 passengers minimum
-



**FSA23-VEH21.0: Heavy Trucks and Buses
Item Group Descriptions**

Buses: 20 to 52 Passenger Capacity Range, Conventional Truck-Type Cutaway Chassis

FSA Item Group Description

- Engine: 240 hp minimum, 6-cylinder diesel
 - Transmission: Allison (or equivalent) 6-speed automatic
 - GVWR: 23,500 lbs. (approximate, sized to meet passenger capacity)
 - Passenger Seating: Seating for 20 passengers minimum
-



**FSA23-VEH21.0: Heavy Trucks and Buses
Item Group Descriptions**

Buses: 33 to 54 Passenger Capacity Range, Commercial-Type, Rear Engine Chassis

FSA Item Group Description

- Engine: 240 hp minimum, 6-cylinder diesel
 - Transmission: Allison (or equivalent) 5-speed automatic
 - GVWR: 36,000 lbs. (approximate, sized to meet passenger capacity)
 - Passenger Seating: Seating for 33 passengers minimum
-



**FSA23-VEH21.0: Heavy Trucks and Buses
Item Group Descriptions**

Buses: 36 to 52 Passenger Capacity Range, Commercial-Type, Front Engine Chassis

FSA Item Group Description

- Engine: 240 hp minimum, 6-cylinder diesel
 - Transmission: Allison (or equivalent) 5-speed automatic
 - GVWR: 36,000 lbs. (approximate, sized to meet passenger capacity)
 - Passenger Seating: Seating for 36 passengers minimum
-



**FSA23-VEH21.0: Heavy Trucks and Buses
Item Group Descriptions**

Cab and Chassis Trucks Electric: 54,000 lbs. GVWR 4x6 Semi Tractor

FSA Item Group Description

- Electric Motor: 340 kW, 455 hp minimum
 - Transmission: 2-speed transmission, differential mounted
 - Batteries: 375 kW storage capacity, frame mounted
 - GVWR: 54,000 lbs.
-



**FSA23-VEH21.0: Heavy Trucks and Buses
Item Group Descriptions**

Cab and Chassis Trucks Electric: Tilt Cab 26,000 lbs. GVWR (DRW) 4x2

FSA Item Group Description

- Electric Motor: 250 kW, 355 hp minimum
 - Transmission: Manufacturer's standard automatic transmission
 - Batteries: 282 kW storage capacity
 - GVWR: 26,000 lbs.
-



**FSA23-VEH21.0: Heavy Trucks and Buses
Item Group Descriptions**

Cab and Chassis Trucks Electric: Conventional Cab 33,000 lbs. GVWR (DRW) 4X2

FSA Item Group Description

- Electric Motor: 260 hp (peak) 185 (continuous)
 - Transmission: Direct drive (no transmission)
 - Batteries: 210 kW battery pack
 - GVWR: 33,000 lbs.
-



**FSA23-VEH21.0: Heavy Trucks and Buses
Item Group Descriptions**

Cab and Chassis Trucks: 17,500 lbs. GVWR (DRW) 4x2

FSA Item Group Description

- Engine: Diesel engine, minimum 190 hp
 - Transmission: Manufacturer's standard automatic transmission
 - GVWR: 17,500 lbs.
-



**FSA23-VEH21.0: Heavy Trucks and Buses
Item Group Descriptions**

Cab and Chassis Trucks: 17,500 lbs. GVWR (DRW) 4x4

FSA Item Group Description

- Engine: Diesel engine, minimum 190 hp
 - Transmission: Manufacturer's standard automatic transmission
 - GVWR: 17,500 lbs.
-



**FSA23-VEH21.0: Heavy Trucks and Buses
Item Group Descriptions**

Cab and Chassis Trucks: 25,500 lbs. GVWR (DRW) 4x2

FSA Item Group Description

- Engine: Diesel engine, minimum 200 hp
 - Transmission: Manufacturers standard automatic transmission or approved equivalent (with PTO provision)
 - GVWR: 25,500 lbs.
-



**FSA23-VEH21.0: Heavy Trucks and Buses
Item Group Descriptions**

Cab and Chassis Trucks: 30,000 lbs. GVWR (DRW) 4x2

FSA Item Group Description

- Engine: Diesel engine, minimum 200 hp
 - Transmission: Manufacturers standard automatic transmission or approved equivalent (with PTO provision)
 - GVWR: 30,000 lbs.
-



**FSA23-VEH21.0: Heavy Trucks and Buses
Item Group Descriptions**

Cab and Chassis Trucks: 52,000 lbs. GVWR Semi Tractor 4x6

FSA Item Group Description

- Engine: 350 hp 6-cylinder diesel engine, manufacturer's 11L minimum
 - Transmission: 10-speed manual with OD or approved equivalent
 - GVWR: 52,000 lbs.
-



**FSA23-VEH21.0: Heavy Trucks and Buses
Item Group Descriptions**

Cab and Chassis Trucks: 52,000 lbs. GVWR Truck 4x6

FSA Item Group Description

- Engine: 350 hp 6-cylinder diesel engine, manufacturer's 11L minimum
 - Transmission: 10-speed manual with OD or approved equivalent
 - GVWR: 52,000 lbs.
-



**FSA23-VEH21.0: Heavy Trucks and Buses
Item Group Descriptions**

Cab and Chassis: Tilt Cab (DRW) 4x2

FSA Item Group Description

- Engine: Manufacturer's standard diesel engine
 - Transmission: Manufacturer's standard automatic transmission
 - GVWR: 12,000 lbs.
-



**FSA23-VEH21.0: Heavy Trucks and Buses
Item Group Descriptions**

Mobile Command Unit/Critical Response Unit

FSA Item Group Description

- Manufacturer's standard equipment and specifications, and if not included, manufacturer installed power windows, power door locks, key FOB keyless entry. Must meet all FDOT and FMVSS safety standards.
-



**FSA23-VEH21.0: Heavy Trucks and Buses
Item Group Descriptions**

Refuse Truck Electric: 60,000 lbs. GVWR 4x6 (cab and chassis only)

FSA Item Group Description

- Motor: Electric powered with the OEM recommended electric motor(s) for this application with no less than a 350kW rating
 - Batteries: Largest available battery for model bid, electric charging system on the truck must be SAE J1772 compliant
 - GVWR: 60,000 lbs.
-



**FSA23-VEH21.0: Heavy Trucks and Buses
Item Group Descriptions**

Refuse Truck: 60,000 lbs. GVWR 4x6 (cab and chassis only)

FSA Item Group Description

- Engine: 300 hp 6-cylinder diesel engine, manufacturer's 11L minimum
 - Transmission: Allison 4500 RDS automatic transmission
 - GVWR: 60,000 lbs.
-



**FSA23-VEH21.0: Heavy Trucks and Buses
Item Group Descriptions**

Refuse Truck: Compact 9.5 Cubic Yds. Self-Loading Refuse Truck

FSA Item Group Description

- Engine: 70 hp diesel engine, EPA compliant
 - Transmission: Hydrostatic transmission, four-wheel drive
 - GVWR: 12,900 lbs.
-



**FSA23-VEH21.0: Heavy Trucks and Buses
Item Group Descriptions**

Tactical Armored Vehicle

FSA Item Group Description

- Engine: 6.7LV-8 Turbo diesel, 330 hp
 - Transmission: 10-speed automatic TorqShift with OD
 - GVWR: GVWR sized to built vehicle (19,500 lbs. approximate)
-



**FSA23-VEH21.0: Heavy Trucks and Buses
Item Group Descriptions**

Terminal Tractor

FSA Item Group Description

- Engine: 173 hp diesel engine
 - Transmission: 7-speed automatic (6 forward, 1 reverse)
-



Ed Costello
Truck Sales Manager

Kenworth of Jacksonville

1121 Suemac Road
Jacksonville, FL 32254
Office (904) 739-2296
Fax (904) 730-3461

May 14, 2024

Nassau County

**2025 Kenworth T880 Day Cab
Florida Sheriff's Association
Contract Number: FSA23-VEH21.0
Specification: 52,000 LB GVWR 4x6 Truck
District: Northern**

	Order Code	Description	Price
A		Florida Sheriff's Association Base T880 - Northern	\$146,040.00
B	0701210	PACCAR MX-13 455 455@1600 1650@900 2024 with Engine Brake	\$2,323.00
C	2016627	Allison 4500RDS 6 Speed Auto Transmission	\$26,801.00
d	2506181	Dana Spicer D2000 Front Axle rated 20K	\$2,284.00
e	3144180	Dual Dana Spicer D46-172 Rear Axle rated at 46K.tandem axles. 12.5mm housing and 2.06in shaft diameter	\$1,247.00
f	DISUNL / 3749209	Rear Suspension: Tandem Chalmers 854-46-H 46k 54in. Axle spacing	\$2,653.00
g	6141200	Full Steel Insert: for 10-5/8 in. or 10-3/4 in. Steel to 284 in. or 2nd insert for 11-5/8 in. steel frame	\$1,667.00
h	DISUNL / 4079060+4277456	11R24.5 tires and 24.5 diameter steel wheels	\$1,134.00
i	3532130	Driver Controlled Differential Lock	\$2,137.00
s	DISUNL / 3495381	Bendix Fusion Adaptive Cruise ACB, Includes 6S/6M ABS System	\$6,630.00
t	DISUNL / 3495243	Bendix Side Object Detection Version 2	\$1,812.00
l	UNPUBBOD / AMR60KTRP	American Roll Off 60,000lb. Capacity with Pioneer Rack and Pinion Tarp System	\$72,292.50
m	Premium+AT-5/300	PACCAR MX Premium <460HP - 5YR/300K MI	\$3,875.00
		TOTAL PRICE:	\$270,895.50

Thank you,

Ed Costello



KENWORTH OF JACKSONVILLE (K440)
1121 SUEMAC RD
JACKSONVILLE, Florida 32254

NASSAU COUNTY
76347 VETERANS WAY
YULEE, Florida 32094
United States of America

Ed Costello
Cell Phone: 904-588-8999
Office Phone: 904-739-2296
Email: edcostello@kwjax.com

David Hearn

Vehicle Summary

	Unit		Chassis	
Model:	T880 Series Conventional	Fr Axle Load (lbs):		20000
Type:	FULL TRUCK	Rr Axle Load (lbs):		46000
Description 1:	ROLL OFF	G.C.W. (lbs):		66000
Description 2:	Chassis 166892			
	Application	Road Conditions:		
Intended Serv.:	Local Pickup & Delivery: Vehicles which	Class A (Highway)		80
Commodity:	Gravel/Crushed Rock/Sand	Class B (Hwy/Mtn)		15
	Body	Class C (Off-Hwy)		5
Type:	End Dump	Class D (Off-Road)		0
Length (ft):	21	Maximum Grade:		6
Height (ft):	12	Wheelbase (in):		256
Max Laden Weight (lbs):	5500	Overhang (in):		75
	Trailer	Fr Axle to BOC (in):		68
No. of Trailer Axles:	0	Cab to Axle (in):		188
Type:		Cab to EOF (in):		263
Length (ft):	0	Overall Comb. Length (in):		379.5
Height (ft):	0			
Kingpin Inset (in):	0	Special Req.		
Corner Radius (in):	0	U.S. Domestic Registry, 50-state.		
	Restrictions			
Length (ft):	120			
Width (in):	102			
Height (ft):	13.5			

Approved by: _____

Date: _____

Note: All sales are F.O.B. designated plant of manufacture.

Bidder: Kenworth of Jacksonville
 Item Make & Model: Kenworth T880
 Item Number: Cab and Chassis Trucks: 52,000 LB GVWR Cab & Chassis Truck 4x6

Manufacturer Order Code	Price	Option Description	Factory Installed or Vendor Installed	Factory Invoice/MSRP Discount % (factory-installed)	Cost-Plus Markup % (vendor-installed)
701118	\$1,104	PACCAR MX-11 430MT 430@1600 1450/1650@900, 2024 with engine brake	Factory	22%	
B 701210	\$2,323	PACCAR MX-13 455MT 455@1600 1850/1650@900, 2024 with engine brake	Factory	22%	
701212	\$2,318	PACCAR MX-13 510 510@1600 1850@1000, 2024 with Engine Brake	Factory	22%	
130341	\$7,913	Cummins X15 450 450@1700 1650@900, 2024 with Intakebrake	Factory	22%	
130352	\$8,830	Cummins X15 500 500@1700 1650@900, 2024 with Intakebrake	Factory	22%	
2058382	\$569	Transmission: Fuller FRO16210C 10-speed	Factory	13%	
2058604	\$5,872	PACCAR TX-12, PO-17F112C, 12-speed, 1750 LB FT	Factory	12%	
2058972	\$1,202	Transmission: Fuller RTO16908LL 10-speed	Factory	15%	
2058446	\$3,799	Transmission: Fuller RTO16913A 13-speed	Factory	15%	
2058744	\$3,879	Transmission: Fuller RTO16918B 18-speed	Factory	15%	
2016612	\$25,219	Transmission: Allison 4000RDS 6-speed, With PTO	Factory	17%	
C 2016627	\$26,801	Transmission: Allison 4500RDS 6-speed, With PTO	Factory	17%	
2058610	\$14,918	PACCAR TX-18 Pro: PXDP-18F118D, 18 Speed	Factory	17%	
66543214	\$874	Fifth Wheel: ILS<=40K air Hol FW35J736XL00 36 in.	Factory	22%	
G 6141200	\$1,667	Full Steel Insert: for 10-5/8 in. or 10-3/4 in. Steel to 284 in. or 2nd insert for 11-5/8 in. steel frame	Factory	22%	
5043550/5243550	\$1,908	All Aluminum Wheels - 22.5	Factory	22%	
5045275/5245275	\$2,410	All Aluminum Wheels - 24.5	Factory	22%	
2503467	\$622	Dana Spicer E-1462W Front Axle rated 14.6K 3-1/2 in drop, wide track for better turning radius. 1	Factory	12%	
d 2505181	\$2,284	Dana Spicer D2000 Front Axle rated 20K -	Factory	12%	
e 3144180	\$1,247	Dual Dana Spicer D46-172 Rear Axle rated at 46K tandem axles. 12.5mm housing and 2.06in shaft diameter	Factory	10%	
3730030	\$2,662	Tandem Kenworth Airglide 400 40K 54 in. axle spacing, 10.5 in. ride height. Includes air suspension dump valve	Factory	22%	
3742020	\$5,063	Tandem Hendrickson Primeax EX462 46K. Steel crossmember & pussets. 54 in. axle spacing, 10 in. ride height. *	Factory	22%	
3740130	\$2,789	Tandem Kenworth Airglide 460 46K 56 in. axle spacing, 10.5 in. ride height. Includes air suspension dump valve 1	Factory	22%	
DOHR	\$1,820	Headrack: Aluminum w/airhouse window, (2) chain boxes, locking chain racks - dealer installed locking chain racks	Vendor		5%
WLK-LB	\$6,520	Hydraulic Wet Line Kit for Low Boy application - dealer installed	Vendor		5%
WLK-DT	\$6,170	Hydraulic Wet Line Kit for trailer dump application - dealer installed	Vendor		5%
7216100	\$1,880	Dual fuel tanks, ADD 100 Gallon RH BOC fuel tank	Factory	22%	
I 3532130	\$2,137	Wheel Differential Lock for Dana Spicer axles	Factory	22%	
3808131	\$13,691	Steerable Lift Axle Pusher / Tag 13,200 lb. rating air lift to include 11R-22.5 tires with steel wheels Requires double frame and rear suspension upgrade	Factory	8%	
3808026	\$16,361	Non-Steerable Pusher Axle Watson Chain AL2200 21K wide track, 11R-22.5 tires with steel wheels Requires double frame and rear suspension upgrade	Factory	8%	
8879917	\$366	Two Additional Outboard Windows - 19in. X 12in.	Factory	22%	
8890135	\$718	Stainless Steel Sunvisor	Factory	22%	
DOFF	\$1,865	Full Fenders for Tandem Axle - Dealer Installed	Vendor		5%
2588005/2329339	\$77,862	Front Drive Axle: Marmon MT-22 Front Drive Axle rated 22K with FABCO 2 Speed Transfer Case	Factory	16%	
ECTFA10074411	\$19,352	14' Steel flat dump, no sides, outside pockets with rubrail, underbody hoist	Vendor		5%
ECTFAC5881	\$21,022	14' - (87) 13/14 yd Maverick for 114" (including HotShift PTO for Allison transmission, 42" sides, standard air tailgate)	Vendor		5%
ECTFAC5691	\$23,956	16' - (87) 17/19 yd Maverick for 138" (including HotShift PTO for Allison transmission, 48" sides, 6 slant rear)	Vendor		5%
ECTFA10074413	\$27,784	16' Trash Dump for 120-126" (including 48" sides, double barn door tailgate, 24" cab protector)	Vendor		5%
ECTFA10074414	\$31,167	18' Trash Dump for 144-150" (including 48" sides, double barn door tailgate, 24" cab protector)	Vendor		5%
ECTFA10074415	\$33,162	20' Trash Dump for 168-174" (including 48" sides, double barn door tailgate, 24" cab protector)	Vendor		5%
ECTFAC5692	\$33,800	14' 11/13 yd Stampede Body, for 114" (including HotShift PTO for Allison trans, 42" sides, standard tailgate)	Vendor		5%
ECTFAC5693	\$34,237	16' 20 yd Stampede Body, for 138" (including HotShift PTO for Allison trans/VMSF, 48" sides, standard tailgate)	Vendor		5%
ECTHLTG	\$2,334	Hi-Lift Tail Gate	Vendor		5%
ECTS4S	\$1,002	Maverick - 60" Sides	Vendor		5%
ECTPH	\$1,810	Pintle Hook with glad hands and 7-pin	Vendor		5%
ECTBV	\$1,299	Dump Bed Vibrator	Vendor		5%
ECTEBC	\$516	Electric Brake Controller	Vendor		5%
ETTCCBGU5-OR-174	\$71,085	Galbreath US-OR-174 60,000 lb. Cable Roll Off	Vendor		5%
ETTCCBGAf-OR-174	\$71,085	Galbreath AF-OR-174 60,000 lb. Cable Roll Off	Vendor		5%
DISUNL 3749209	\$2,603	10% Discount off current MSRP for any options listed. This discount does not apply to any other make or model Rear Suspension Tandem Chalmers 854-46-H 46K 54in. Axle spacing	Factory	22%	
3495381	\$6,630	Bendix Fusion Adaptive Cruise ACB, Includes 6S/6M ABS System	Factory	22%	
3495243	\$1,812	Bendix Side Object Detection Version 2	Factory	22%	
4078060+4277456	\$1,134	11R24.5 tires and 24.5 diameter steel wheels	Factory	22%	

L	UNPUBBOD		Unpublished bodies are available at cost plus 5% including fees	Vendor		5%
	AMR60KTRP	\$72,293	American Roll Off 60,000lb. Capacity with Pioneer Rack and Pinion Tarp System	Vendor		5%
	9201829	\$3,885	EW: US Basic Vehicle 5 year/200,000 miles.	Factory	0%	
	9201832	\$8,710	EW: US Basic Vehicle 5 year/500,000 miles.	Factory	0%	
	9201928	\$1,110	EW: US Heater & Air Conditioner 5 year/300,000	Factory	0%	
M	Premium+AT-5/300	\$3,875	PACCAR MX Premium <460HP - 5YR/300K MI	Factory	0%	
	Premium+AT-5/400	\$5,345	PACCAR MX Premium <460HP - 5YR/400K MI	Factory	0%	
	Premium+AT-5/500	\$7,020	PACCAR MX Premium <460HP - 5YR/500K MI	Factory	0%	

Bid Award

Contract: FSA23-VEH21.0, Heavy Trucks and Buses

Group: Cab and Chassis Trucks: 52,000 lbs. GVWR Truck 4x6

Item: 62, Kenworth, T880, T880

Zone	Rank	Vendor	Price	Build File	Options File
Western	Primary	Truckworx Kenworth	\$173,342.00	Build	Options
Northern	Primary	Kenworth of Jacksonville	\$146,040.00	Build	Options
Central	Primary	All Roads Kenworth, LLC.	\$141,729.00	Build	Options
	Alternate	Florida Kenworth, LLC	\$142,927.00	Build	Options
Southern	Primary	All Roads Kenworth, LLC.	\$141,729.00	Build	Options
	Alternate	Florida Kenworth, LLC	\$142,927.00	Build	Options



Std/ Opt	Description	Weight
Model		
S	T880 Series Conventional	15,549
S	T880	0
O	Chassis Operation Will Not Incl. Stationary application. Stationary operation is defined as running the engine under load while stationary at a substantial fraction of engine gross horsepower (60% or greater) for an extended period of time (longer than 5 - 10 minutes).	0
O	EPA Clean Idle Label - PACCAR MX Engines	0
S	Non-Sleeper w/ Rear Axle Capacity less than 59K.	0
O	State of Registry: Florida	0

Engine & Equipment

S	PACCAR MX-13 455 455@1600 1650@900, 2024 With Engine Brake	0
	N09020 AE001 NO....ENBL MX RETARDER IN NEUTRAL	
	N08200 AE002 650...IDLE TARGET	
	N09100 AA003 65....CC MAX TARGET SPD	
	N09110 AA004 10....CC MIN ENABLE SPD	
	N09120 AA005 OFF...DYNAMIC CC ENABLE	
	N09440 AA061 2000..CAB:MAX ENG SPD-ACCEL CNTRL	
	N09430 AA062 2000..CAB: MAX ENG SPD - SW CNTRL	
	N09420 AA063 6....CAB: MAX VEH SPD	
	N09510 AA065 800...CAB: DEDICATED PRESET "-"	
	N09520 AA066 900...CAB: DEDICATED PRESET "+"	
	N09780 AA049 CNCL..CAB: CUSTOM PRESET 1 FUNC	
	N09640 AA050 0....CAB: CUSTOM PRESET 1	
	N09790 AA051 CNCL..CAB: CUSTOM PRESET 2 FUNC	
	N09650 AA052 0....CAB: CUSTOM PRESET 2	
	N09800 AA053 CNCL..CAB: CUSTOM PRESET 3 FUNC	
	N09660 AA054 0....CAB: CUSTOM PRESET 3	
	N09500 AA060 OFF...CAB: PRESET +/- SW TYPE	
	N09630 AA067 TRQ...CAB:ACCEL PEDAL TYPE IN PTO	
	N09400 AA068 YES...CAB:ACCEL ACTV IN CAB PTO	
	N09470 AA055 ON A..CAB: CLUTCH INTLK	
	N09840 AA056 OFF...CAB: CUSTOMER INTLK	
	N09480 AA057 ON A..CAB: NEUTRAL INTLK	
	N09460 AA058 ON A..CAB: PARK BRK INTLK	
	N09490 AA059 ON A..CAB:SER BRK INTLK:NO PTO	
	N09540 AA074 2000..REM:MAX ENG SPD-ACCEL CNTRL	
	N09530 AA075 2000..REM:MAX ENGSPD-SW/TSC1 CTRL	
	N09610 AA077 800...REM: DEDICATED PRESET "-"	
	N09620 AA078 900...REM: DEDICATED PRESET "+"	
	N09810 AA043 CNCL..CAB/REM:CUSTOM PRESET1 FUNC	
	N09670 AA044 750...CAB/REM: CUSTOM PRESET 1	

Price Level: January 1, 2024

Deal: ROLL OFF

Printed On: 5/15/2024 7:25:55 AM

Date: May 15, 2024

Quote Number: QUO-1032331-F3F1V5



Std/ Opt	Description	Weight
	N09820 AA045 CNCL...CAB/REM:CUSTOM PRESET2 FUNC	
	N09680 AA046 850...CAB/REM:CUSTOM PRESET 2	
	N09830 AA047 CNCL...CAB/REM:CUSTOM PRESET3 FUNC	
	N09690 AA048 950...CAB/REM: CUSTOM PRESET 3	
	N09600 AA079 OFF...REM: PRESET +/- SW TYPE	
	N09410 AA069 YES...PTO REM PEDAL ENABLE	
	N09560 AA070 ON AD.REM: CLUTCH INTLK	
	N09700 AA071 OFF...REM: CUSTOMER INTLK	
	N09570 AA072 ON AD.REM: NEUTRAL INTLK	
	N09580 AA073 ON AD.REM:SER BRK INTLK:NO PTO	
	N09550 AA076 650...REM: MIN ENG SPD	
	N09450 AA064 650...CAB: MIN ENG SPD	
	N09760 AA009 5.....DRIVER REWARD VEH SPD BONUS	
	N09770 AA010 -5.....DRIVER REWARD VEH SPD PNLTY	
	N09750 AA013 NONE..OFFSET MODE	
	N09720 AA015 3.....MIN SPD FOR DR SHIFT AID	
	N09730 AA016 1.....DSA LOWEST ACTV GEAR	
	N09740 AA017 6.....DSA HIGHEST ACTV GEAR	
	N09340 AA019 YES...EIST PARK BRK RESET ENABLE	
	N09300 AA022 30....EIST LO CLNT TEMP OVERRIDE	
	N09290 AA023 80....EIST HI AMBAIR TEMP OVRDRDE	
	N09280 AA024 39....EIST LO AMBAIR TEMP OVRDRDE	
	N09260 AA025 5.....EIST PTO MAX IDLE TIME	
	N09230 AA026 5.....EIST PARKED MAX IDLE TIME	
	N09220 AA027 5.....EIST STANDSTILL IDLE TIME	
	N09240 AA029 YES...EIST RESET FROM ENG LOAD	
	N09250 AA030 NO....EIST OVERRIDE FROM ENG LOAD	
	N09200 AA031 0.....EIST EXPIRATION DISTANCE	
	N09310 AA032 YES...EIST ACCEL PEDAL RESET	
	N09330 AA033 YES...EIST SERVICE BRK RESET	
	N09320 AA034 YES...EIST CLUTCH PEDAL RESET	
	N09270 AA035 YES...EIST PTO OVERRIDE	
	N08030 AA086 65....MAX ACCEL PEDAL VEH SPD	
	N08000 AA087 0.....VSL EXPIRATION DISTANCE	
	N08020 AA088 65....LRSL SPD LMT	
	N09350 AA042 1900..FAST IDLE CNTRL MAX ENG SPD	
	N09050 AA037 4.....DSL SPD OFFSET	
	N09040 AA038 2.....AUTO RTRDR VEH SPD OFFSET	
	N09030 AA039 0.....TIME DELAY FOR RTRDR ACT	
	N09130 AA006 MT....MULTI TORQUE IN CC	
	N09080 AQ001 4.....PCC Negative Offset	
	N09090 AQ002 4.....PCC Positive Offset	
	N09710 AA089 NO....REMOTE INPUTS IN CAB PTO	
	N08200 AE002 650...IDLE TARGET	
O	EPA Emissions Warranty Engine	0
S	PremierSpec	0
O	Engine Monitoring Protection -Derate- PACCAR MX Engine Parameter.	0

Price Level: January 1, 2024

Deal: ROLL OFF

Printed On: 5/15/2024 7:25:55 AM

Date: May 15, 2024

Quote Number: QUO-1032331-F3F1V5



Std/ Opt	Description	Weight
O	Gearing Analysis: Performance power before economy results.	0
O	Customer's Typical Operating Spd: 64 MPH	0
O	MX Retarder State Cruise Control On Manual Mode Selecting this code will program the engine controller to make manual mode available when cruise control is on, but not set, and the engine brake switch is on. Manual mode means the engine retarder activates whenever the throttle pedal is not depressed. 2013+	0
	RegistrationYear Year of Registration: 2024	0
O	Effective VSL Setting NA	0
O	Engine Idle Shutdown Timer Disabled	0
O	Eff EIST NA Expiration Miles Use only with MX and Cummins engines	0
S	Air Compressor: WABCO 25.9 CFM PACCAR MX 2017+ 440cc Air Compressor	0
S	Air Cleaner: Composite Firewall Mounted PACCAR or Cummins Engines	0
S	Fan hub: Horton 2-Speed for PACCAR MX	0
S	Cooling module: 1330 square inches. Includes aluminum radiator core, aluminum charge air cooler, translucent surge tank and washer bottle, silicone hoses, and extended life coolant.	0
O	Bug Screen: Between Hood & Grille	2
S	EXH: Single Can 2024 RH Under with RH Side-of-Cab Vertical Tailpipe	0
O	Tailpipe: 5 in. single 24 in. 45 degree curved.	-3
S	Fuel Filter: PACCAR Extended Service Interval On-Engine Fuel/Water Separator. 2021 and Later Emissions MX Engines only.	0
S	Run Aid:Fuel Heat *For Fuel Filter	0
S	Start Aid:12V Heat *For Fuel Filter	0
S	Alternator: PACCAR HDS 160 AMP Brushed	0
O	Batteries: 2 PACCAR GP31 Threaded Post (700-730) 1400-1460 CCA dual purpose.	-57
S	PACCAR Premium 12V Starter with PACCAR MX Engines PACCAR 12 volt electrical system. With centralized power distribution incorporating plug-in style relays. Circuit protection for serviceability, 12-volt light system w/circuit protection circuits number & color coded.	0
S	12V Low Voltage Disconnect for Battery Protection	0

Price Level: January 1, 2024

Deal: ROLL OFF

Printed On: 5/15/2024 7:25:55 AM

Date: May 15, 2024

Quote Number: QUO-1032331-F3F1V5



Std/ Opt	Description	Weight
S	Remote PTO/Throttle, 12-Pin, Engine Bay Remote Control Provision	0
Transmission & Clutch		
O	Transmission: Allison 4500RDS 6-speed, With PTO drive gear. No Retarder. 6th Generation controls. For vocational applications. Includes shift control, transmission oil temperature gauge, oil level sensor & heat exchanger. Transynd transmission fluid is standard on all Allison 1000, 2000, 3000 & 4000 series transmissions.	478
O	Driveline: 3 Dana 1810 Heavy-Duty W/2 Centerbearings *Heavy duty is 1810HD series.	0
O	Torque Converter Included W/ Allison Transmission.	0
O	Pushbutton Control Center Console Mounted. Class 8 with Allison Transmission.	0
O	Allison Fuel Sense: Delete	0
O	Allison Neutral at Stop	0
O	Customer Installed Transmission PTO in the LH Mounted position (8 o'clock) for Allison 3000 & 4000 transmissions.	0
Front Axle & Equipment		
S	PACCAR FX-20 Front Axle rated at 20K 4" drop standard track	0
O	Front Brakes: 22K Bendix ES S-Cam 16.5x6 in.	-46
O	Front Brake Drum: 22K 16.5x6 in. cast.	104
O	Front Hubs Iron Hub Pilot 20,000 lbs. 10 Bolt 16.5x6in. or 7in. or air disc brakes. 10 Bolt, 11-1/4 in. bolt circle. Consider Wheelguards (5850002) with aluminum wheels.	80
S	ConMet PreSet Plus Hub Package; Front Axle.	0
S	Hubcap: Front Vented.	0
O	Front Auto Slack Adjuster for Drum Brakes.	0
S	Front Springs: Taperleaf 20K W/ Shock Absorbers w/ maintenance-free elastomer spring pin bushings. Standard with rubber pins except for C500 which has threaded pins. Not available on W900L. W900B use 2866021.	0
O	Dual Power Steering Gear: 16-22K TRW THP60 Not for use on T3.	54
S	Power Steering Cooler:Radiator Mounted Air-to-Oil	0
O	Front Frame Raised: 1/2 in.	0
O	Threaded Bushings for Taperleaf Spring	0

Price Level: January 1, 2024

Deal: ROLL OFF

Printed On: 5/15/2024 7:25:55 AM

Date: May 15, 2024

Quote Number: QUO-1032331-F3F1V5



Std/ Opt	Description	Weight
	16K, 18/20K, 22K, 40K replacing rubber.	
Rear Axle & Equipment		
O	Dual Dana Spicer D46-172H Rear Axle rated at 46K. w/ 16mm housing and 2.06in. shaft diameter. Tandem rear axles.	-158
O	Rear Axle Ratio - 4.78.	0
O	Dual Rear Brakes 16-1/2x7 in. to 46K; Bendix ES-extended service S-cam.	0
O	Dual Rear Brake Drums: Cast. For use with 16.5X7" or 16.5X8.625" brake.	208
S	Dual Rear Hubs: Aluminum Hub Pilot 46K; 11.25" bolt circle. Requires "R" series outer ends.	0
S	ConMet PreSet Plus Hub Package; Dual Rear Axle.	0
O	Tandem Rear Axle Automatic Slack Adjusters. For use with drum brakes.	0
O	Spring Brake: 3030 High Output Dual. For drum brakes.	0
S	Bendix 6S/6M Anti-Lock Brake System W/ Air traction control (ATC) and electronic stability program (ESP) for full truck. Must code for additional body information.	0
O	Bendix Side Object Detection Version 2 sensor on RH side, with increased field of view and enhanced detection.	0
O	Non-Adjustable Headway Distance For ACC at 2.8 Sec	0
O	Standard Headway Distance Warnings For Use with ACC (1.5, 1.0, 0.5 S)	0
O	Bendix Fusion Adaptive CC W/ACB rel 2.2 W/Adjacent Lane and Highway Departure AEB W/O Video Recording	0
O	Inverted Chambers for 16-1/2 x 7 in. Brakes; Replaces standard mount w/ higher mount.	0
O	Interaxle Driveline:1 Dana 1710 Series Tandem Rear Axels Only.	-12
O	20-33 Cubic Yard Dump	0
O	Wheel Differential Lock for Dana Spicer Axles D40-170(P)/D46-170(H)(P)(WT) forward rear axle & rear rear axle.	112
O	Rear suspension: Tandem Chalmers 854-46-H 46K. 54 in. axle spacing. Unladen Height: 12.5 in. Laden Height: 10.1 in. Standard restrictor can.	226
O	Delete Standard Heavy-Duty Air Springs for Rear suspension.	-28
Tires & Wheels		
O	Front Tires: Michelin XZY3 425/65R22.5 20PR 44.7 in. Diameter, All Position. 20.6in. SLR.	38
O	Rear Tires: Michelin X Multi D+ 11R24.5 16PR	0

Price Level: January 1, 2024

Deal: ROLL OFF

Printed On: 5/15/2024 7:25:55 AM

Date: May 15, 2024

Quote Number: QUO-1032331-F3F1V5



Std/ Opt	Description	Weight
O	Rear Tire Quantity: 8	0
O	Front Wheel: Alcoa 82362 22.5x12.25 aluminum, with Lvl One [TM] finish High Polish, hub-pilot mount. 11400lb. maximum rating. Super single. Standard track axles may be over 102 in. w/425 tires. Air disc brake compatible.	-10
O	Rear Wheel: Accuride 50641 24.5X8.25 steel ACCU-LTE. Steel Armor[TM] powder coat, hub-pilot mount. 7400lb. maximum rating. 5-hand hole.	64
O	Powder Coat White Steel Wheel. Use in Conjunction with front, dual front, rear, spare or lift axle wheel code(s). All wheels on chassis must have same finish color.	0
O	Rear Wheel/Rim Quantity: 8	0
Frame & Equipment		
O	Frame Rails: 10-5/8 x 3-1/2 x 5/16 in. Steel to 337 in. to 416 in. Truck frame weight is 2.91 lb.-in. per pair of rails. Section modulus is 14.80, RBM is 1,776,000 in-lbs per rail. Frame rail availability may be restricted based upon application, axle/suspension capacity, fifth wheel setting, or component/dimensional specifications. The results of the engineering review may result in a change to the requested frame rail. If a change is required Kenworth Application Engineering will advise the dealer of the appropriate material specification for a substitute rail.	320
O	Full Steel Insert: for 10-5/8 in. or 10-3/4 in. Steel 337 in. to 416 in. or 2nd insert for 11-5/8 in. steel frame. Adds 1,149,000 in-lb to main rail RBM. Truck insert weight is 2.05 lb.-in. per pair of rails. Full frame insert length is equal to wheelbase plus rear frame cutoff plus dimension forward of front axle by model. See databook addendum section 7.2.	722
O	Bumper: Straight Steel, Painted Channel. Requires a bumper setting code.	50
S	48.5 in. Bumper Setting. Requires a Bumper Code.	0
O	Battery Box Cantilever Aluminum BOC with Painted smooth aluminum cover.	10
O	Battery Box Location: RH Side.	15
S	T470,C5, T6, T8 Non-Polished DPF/SCR or CNG Cover diamond plate w/ step. For use w/ 2010 or later exhaust systems. For T8, use extended length non-polished battery box on opposite rail to match the length of under cab components. End plates will be painted standard black frame color.	0
O	Width Across Front Tires Exceeds 102 inches. Dealer to review delivery constraints w/transporter.	0
O	Final End-of-Frame Cut-Off Dimension Will be modified to 61 in. to 65 in.	0
O	Two Rams Horn Open Rear Tow Hooks, Not for trailer towing.	17

Price Level: January 1, 2024

Deal: ROLL OFF

Printed On: 5/15/2024 7:25:55 AM

Date: May 15, 2024

Quote Number: QUO-1032331-F3F1V5



Std/ Opt	Description	Weight
S	Rear Mudflap Arms: Betts B-25 Standard-Duty, straight. Includes B1732 mounting brackets as standard.	0
S	Rear Mudflap Shields: White Plastic Antisail W/ Kenworth logo.	0
O	Square End-of-Frame W/ Crossmember; Non-Towing.	30
Fuel Tanks & Equip		
O	Fuel Tank: 100 US Gallon 24.5 in. Aluminum Under replace. Class 8 fuel tanks w/o locking caps include an anti-siphon device on the filler neck.	0
S	Small Round DEF Tank, 14 Gallons. The DEF tank will be located on the side you specified. If you have specific configuration or body builder concerns, please utilize the Custom Frame Layout option. Standard capacity is calculated by fuel capacity of the vehicle and will accommodate two diesel fill-ups for every DEF fill-up. For 1:1 DEF fuel fill ratio, add 7889204.	0
O	Minimum Required DEF to Fuel Fill Ratio.	0
S	Anti-Siphon Device in Fuel Tank Filler Neck. For any number of fuel tanks.	0
S	DEF Tank Location is LH.	0
O	Location: 100 gal fuel tank LH under cab	0
Cab & Equipment		
S	Cab: Stamped Aluminum Cab with Panoramic Curved glass windshield. Standard with stamped aluminum doors, heavy duty in-swinging hinges, and triple sealed doors. Manufactured using self- piercing rivets and structural adhesive. Includes LED exterior marker lights and turn signals.	0
S	Hood: T880 Set-Back Short Length. 116.7 inch BBC W/ Std Bumper.	0
S	Cab HVAC - Day Cab and 40 in. Sleeper System With Defrost, A/C, and 48,000 BTU/hr Heater. Includes automatic temperature control with one touch defrost operation and dash mounted cab temperature and solar intensity sensors. Pleated fresh air filter and cabin recirculation air filter standard. The Kenworth HVAC system is designed to provide optimal heating and cooling in all operating environments without need for additional insulation. Cab HVAC without sleeper heater AC is available with 40in sleeper.	0
O	Kenworth Smartwheel: 18 in. Leather Wrapped With Integrated Radio and Cruise Controls.	2
O	Column Mtd Retarder Control, RH Side Use with Manual & Allison Transmissions Only.	0
S	Adjustable Telescoping Tilt Steering Column.	0
O	Information for Customer-Installed PTO Muncie 10-bolt.	0
O	Dash Switch:1st Allison-Mounted PTO.	0

Price Level: January 1, 2024

Deal: ROLL OFF

Printed On: 5/15/2024 7:25:55 AM

Date: May 15, 2024

Quote Number: QUO-1032331-F3F1V5



Std/ Opt	Description	Weight
	Electric switch and wiring are factory-installed to control the 1st Allison Trans mounted PTO.	
S	Gauge: DD Virtual Gauge - Oil Temp Engine	0
S	Gauge: DD Virtual Gauge - Manifold Pressure Boost	0
S	Gauge: DD Virtual Gauge - Engine Percent Torque	0
S	Main Instrument Package: 15" Digital Display. Includes Speedometer, Tachometer, Primary Air Pressure, Secondary Air Pressure, Fuel Level #1, DEF Level, DPF Filter Status, Fuel Economy, Oil Pressure, Coolant Temp, OAT and Voltmeter, and Air Application.	0
S	Interior Color: Slate Gray	0
S	Interior Package: Vantage Daycab Includes durable headliner and vinyl sidewalls with geometric patterned trim and anodized aluminum accents throughout. Convenient overhead storage cubbies, full size glove box, two center console cupholders, and large door pad map pocket. Standard LH/RH power windows, electric door locks, interior LED lighting, nighttime-friendly red ambient lighting for dash and footwell, and door mounted courtesy light. Includes two standard 12V power outlets. Driver sunvisor includes strap.	0
S	Rubber Floormat	0
O	Driver Seat: GT701 HB with DuraCloth material. The GT701 is standard with a single air bag, scissor linkage seat suspension. It includes a single chamber lumbar support, 10in Fore/Aft adjustment, 7in Up/Down adjustment, 2.5in pan extension, 51 degree seat back recline, and 16 degree full seat tilt. Includes 3-point matching seat belts. DR seat standard w/ dual armrests.	0
O	Rider Seat: GT100 Toolbox HB with DuraCloth Material. The GT100 seats are standard with fixed base. Includes 3-point matching seat belts. Rider seat standard w/ LH armrest.	0
O	Seat Color: Gray	0
O	Kenworth Radio DEA710 AM/FM/WB/USB, Bluetooth	0
S	Base Level Audio System - Daycab:High Performance Door Speakers.	0
S	Turn Signal: Non-Self Cancelling	0
S	LH and RH Trip Ledge Rain Deflectors	0
S	Kenworth TruckTech+: This system provides the World's Best reporting of engine and aftertreatment fault codes, as well as enhanced support for the truck owner through rapid communication of fault severity and recommended	0

Price Level: January 1, 2024

Deal: ROLL OFF

Printed On: 5/15/2024 7:25:55 AM

Date: May 15, 2024

Quote Number: QUO-1032331-F3F1V5



Std/ Opt	Description	Weight
	actions. This is standard on all Kenworth models with a PACCAR MX engine, Cummins X15 engine, PX engine or Natural Gas engine.	
O	Grabhandle: LH, Exterior, Side of Cab - Ergonomic Grab Handle Mounted To The Left Hand Exterior Of The Cab For Entry and Exit.	3
S	Dual Cab Interior Grabhandles: A Pillar Mounted Dash Wrap and B Pillar Mounted Grabhandles	0
S	Kenworth Daylite Door With Standard LH/RH electric door locks and LH/RH electric window controls.	0
S	Single Air Horn Under Cab.	0
S	Look-Down, Pass. Door, Black 11x6	0
O	Mirror: RH Hood Mounted, Rectangle 8x6, Chrome	4
O	Mirror: LH Hood Mounted, Rectangle 8x6, Chrome	4
S	Aero Mirror: Dual Kenworth Aerodynamic Motorized heated mirrors, 7in X 13in with cab color mirror shell and black mirror arms. Also includes LH/RH heated 6in X 7in convex mirrors. Mirror brackets set for 8-1/2 ft load width. Mirror controls located on driver side door pad.	0
S	Rear Cab Stationary Window 19in x 36in	0
S	One-Piece Bonded-In Windshield With Curved Glass. Standard.	0
S	Exterior Stainless Steel Sunvisor.	19
S	Wheelwell Fender Extension: 2.5 Inches	0
S	Kenworth Cab/Sleeper Air Suspension.	0
Lights & Instruments		
S	Headlamps: SAE Dual Halogen Complex Reflector	0
S	Marker Lights: Five, Rectangular, LED	0
S	Turn Signal Lights: Flush Mounted LED. Mounted at top of fender wheel arc.	0
S	LED Stop,Turn,Tail: With Two LED Backup Lights and With An LED License Plate.	0
O	Dual Low-Profile LED Amber Revolving Beacon centered over door.	7
O	Daytime Running Lamps.	0
S	Marker Lights: Interrupter Switch. Included in Turn Signal For All Models Except T3. The T3 Switch Is In The Dash.	0
O	Brake Lights on when Engine Brake Active.	0

Price Level: January 1, 2024

Deal: ROLL OFF

Printed On: 5/15/2024 7:25:55 AM

Date: May 15, 2024

Quote Number: QUO-1032331-F3F1V5



Std/ Opt	Description	Weight
	Can only be selected when chassis also has engine brake. Cannot be used with options to delete engine brake.	
O	Reflectors: Two Midframe	0
O	Electric Backup Alarm: Meets SAE J994 & OSHA requirements.	4
O	Polyswitches Replacing Fuses. Switch Will automatically reset after removal of excess load.	0
Air Equipment		
S	Air Dryer: Bendix AD-HF Puraguard Heated	0
S	Moisture Ejection Valve W/ Pull Cable Drain.	0
S	Nylon Air Tubing in Frame & Cab, Excluding Hoses subject to excessive heat or flexing.	0
Extended Warranty		
O	Base Warranty - PACCAR MX-11 & MX-13 Engine 24 months / 250,000 miles / 400,000 km / 6250 hours.	0
S	Base Warranty - Standard Service Heavy Duty 12 months / 100,000 miles / 160,000 km.	0
O	TruckTech+ RD/OTA - 5YR Sub PACCAR MX Engines	0
O	Base Warranty: Emissions 5YR/100K MI - EPA Engine	0
Miscellaneous		
U	PREPAID FREIGHT ADJUSTMENT <i>Narr PREPAID FREIGHT ADJUSTMENT PREPAID FREIGHT ADJUSTMENT PREPAID FREIGHT ADJUSTMENT</i>	0
O	GHG Secondary Manufacturer: Does Not Apply	0
O	Additional Lead Time Required for Off Highway & /or specialty component truck.	0
S	VMUX Architecture	0
Promotions		
U	2024 SCHEDULING CODE - PROGRAM <i>Narr 2024 SCHEDULING CODE - PROGRAM</i>	0
U	TC570 2H 2024 CLASS 8 SALES PROGRAM <i>Narr TC570 2H 2024 CLASS 8 SALES PROGRAM</i>	0
Paint		
O	Paint Color Number(s). N9702 A - L0006 WHITE N9770 BUMPER N0001 BLACK	0

Price Level: January 1, 2024

Deal: ROLL OFF

Printed On: 5/15/2024 7:25:55 AM

Date: May 15, 2024

Quote Number: QUO-1032331-F3F1V5



<i>Std/ Opt</i>	<i>Description</i>	<i>Weight</i>
N9720 FRAME N0001	BLACK	
O	Steel Bumper Painted Frame Color	0
O	Day Cab Bulk Paint	0
O	Day Cab Standard Paint	0
S	1 - Color Paint - Day Cab Color will be White if no other color is specified.	0
S	Base Coat/ Clear Coat. The Kenworth Color Selector contains additional instructions, as well as information on Kenworth paint guidelines and surface finish applications. Kenworth is standard with Dupont Imron Elite paint.	0

Special Requirements

- Special Requirement 1 0098025
- Special Requirement 2
- Special Requirement 3
- Special Requirement 4

Order Comments

Price Level: January 1, 2024

Deal: ROLL OFF

Printed On: 5/15/2024 7:25:55 AM

Date: May 15, 2024

Quote Number: QUO-1032331-F3F1V5



Total Weight (lbs)

17,808

Prices and Specifications Subject to Change Without Notice.

Unpublished options may require review/approval.

Dimensional and performance data for unpublished options may vary from that displayed in CRM.

PRICING DISCLAIMER

While we make every effort to maintain the web site to preserve pricing accuracy, prices are subject to change without notice. Although the information in this price list is presented in good faith and believed to be correct at the time of printing, we make no representations or warranties as to the completeness or accuracy of this information. We reserve the right to change, delete or otherwise modify the pricing information which is represented herein without any prior notice. We carefully check pricing specifications, but occasionally errors can occur, therefore we reserve the right to change such prices without notice. We disclaim all liability for any errors or omissions in the materials. In no event will we be responsible for any damages of any nature whatsoever from the reliance upon information from these materials. Please check your order prebills to confirm your pricing information

Price Level: January 1, 2024

Deal: ROLL OFF

Printed On: 5/15/2024 7:25:55 AM

Date: May 15, 2024

Quote Number: QUO-1032331-F3F1Y5



Shipping Destinations

Intermediate Destination:

Final Destinations	Quantity
--------------------	----------

HORIZONTAL DIMENSIONS

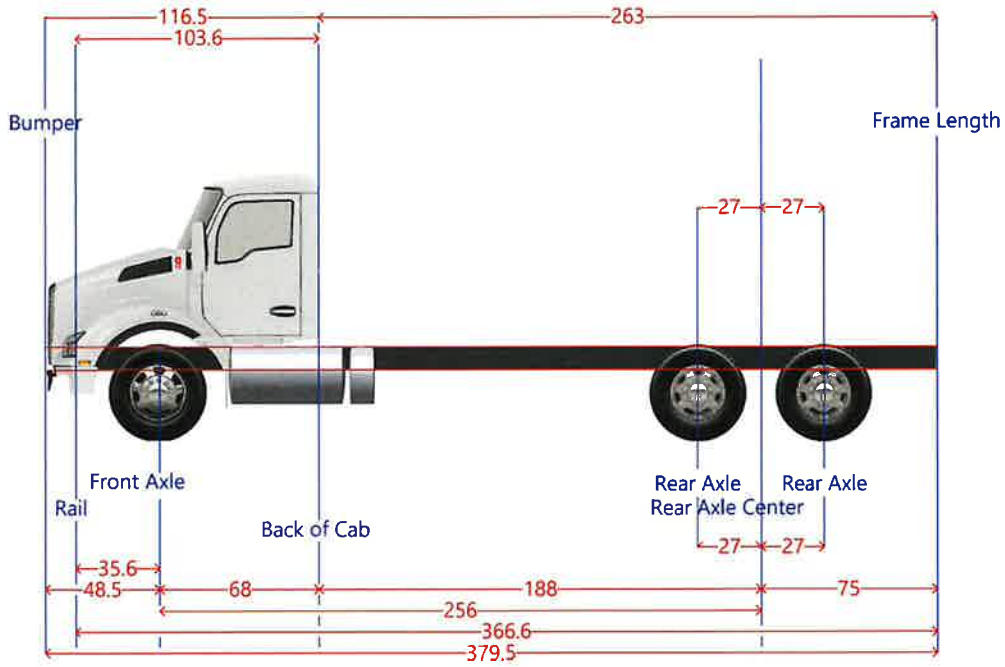

Dimension	Measurement	Start	End
Axle Spacing	54	229	233
Bumper to Back of Cab	116.5	-48.5	68
Bumper to Front Axle	48.5	-48.5	0
Bumper to Front Frame	12.9	-48.5	-35.6
Cab to End of Frame	263.0	63	331
Cab to Rear Axle	188.0	68	256
Effective Bumper to Back Of Cab	116.5	-48.5	63
Frame Length	366.6	-35.6	331
Front Axle to Back of Cab	63.0	0	68
Front of Frame to Axle	35.6	-35.6	0
Load Space	263.0	68	331
Overall Length	379.5	-48.5	331
Overhang	75.0	256	331
Pusher Offset #1	27.0	229	256
Pusher Offset #2	27.0	219	256
Pusher Offset #3	27.0	229	256
Tag Offset	27.0	256	283
Wheelbase	256	0	256

WEIGHT DISTRIBUTION

Model: T880

Actual performance of a specific unit can be affected by your operating conditions. The performance calculations should only be used as a guideline.



Recommended payload center of gravity to achieve specified ground loads, measured from centerline of drive axle(s): 48 in. from the centerline of the drive axle(s).

Weight (lbs)	Front	Rear	Total
Chassis	10589	7219	17808
Tools/Driver	284	91	375
Fuel & DEF	652	196	849
Max Payload	8474	38494	46968
Auxiliary Payload	0	0	0
Total	20000	46000	66000
Specify Ground Load	20000	46000	

Auxiliary Payload

Item	Location from FA CL	Weight	Point Description
Load Point #1			
Load Point #2			
Load Point #3			
Component(s)		0	Composite Totals

Fifth wheel slide length is 0 inches
 Selected rearmost setting is 0 inches
 Wheelbase measurement: 256 inches
 Overhang measurement: 75 inches

FRAME LAYOUT

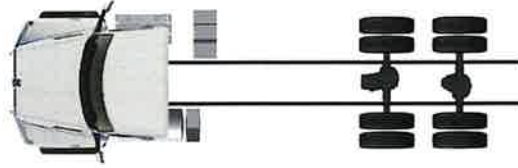

Note: Optional content may be displayed. The order has not yet received an engineering review. The actual arrangement of components may not be exactly as pictured. Additional changes may be made to the layout by Kenworth. Add a Custom Frame Layout code if an exact layout is required.

Selected Options (Wheelbase: 256)

Sales Code	Description	Length	Side
7210100	Fuel Tank 100 US Gallon 24.5 in. Aluminum Under	50	Left
7722153	Small Round DEF Tank, 14 Gallons.	10.2	Left
6400634	Battery Box Cantilever Aluminum BOC with Painted	13.2	Right



CERTIFICATE OF LIABILITY INSURANCE

DATE (MM/DD/YYYY)

5/29/2024

THIS CERTIFICATE IS ISSUED AS A MATTER OF INFORMATION ONLY AND CONFERS NO RIGHTS UPON THE CERTIFICATE HOLDER. THIS CERTIFICATE DOES NOT AFFIRMATIVELY OR NEGATIVELY AMEND, EXTEND OR ALTER THE COVERAGE AFFORDED BY THE POLICIES BELOW. THIS CERTIFICATE OF INSURANCE DOES NOT CONSTITUTE A CONTRACT BETWEEN THE ISSUING INSURER(S), AUTHORIZED REPRESENTATIVE OR PRODUCER, AND THE CERTIFICATE HOLDER.

IMPORTANT: If the certificate holder is an ADDITIONAL INSURED, the policy(ies) must have ADDITIONAL INSURED provisions or be endorsed. If SUBROGATION IS WAIVED, subject to the terms and conditions of the policy, certain policies may require an endorsement. A statement on this certificate does not confer any rights to the certificate holder in lieu of such endorsement(s).

PRODUCER USI Insurance Services, LLC 4600 Touchton Rd Ste 275 Jacksonville, FL 32246 904 450-4700	CONTACT NAME: Lisa Keelor PHONE (A/C, No, Ext): 904 450-4700 E-MAIL ADDRESS: lisa.keelor@usi.com		FAX (A/C, No):
	INSURER(S) AFFORDING COVERAGE		NAIC #
INSURED Kenworth of Jacksonville, Inc. *SEE BELOW LIST OF OTHER NAMED INSUREDS* 1121 Suemac Rd Jacksonville, FL 32254	INSURER A : National Union Fire Ins Co of Pitts, PA		19445
	INSURER B : Starstone Specialty Ins. Co.		44776
	INSURER C :		
	INSURER D :		
	INSURER E :		
	INSURER F :		

COVERAGES	CERTIFICATE NUMBER:	REVISION NUMBER:
------------------	----------------------------	-------------------------

THIS IS TO CERTIFY THAT THE POLICIES OF INSURANCE LISTED BELOW HAVE BEEN ISSUED TO THE INSURED NAMED ABOVE FOR THE POLICY PERIOD INDICATED. NOTWITHSTANDING ANY REQUIREMENT, TERM OR CONDITION OF ANY CONTRACT OR OTHER DOCUMENT WITH RESPECT TO WHICH THIS CERTIFICATE MAY BE ISSUED OR MAY PERTAIN, THE INSURANCE AFFORDED BY THE POLICIES DESCRIBED HEREIN IS SUBJECT TO ALL THE TERMS, EXCLUSIONS AND CONDITIONS OF SUCH POLICIES. LIMITS SHOWN MAY HAVE BEEN REDUCED BY PAID CLAIMS.

INSR LTR	TYPE OF INSURANCE	ADDL INSR	SUBR WVD	POLICY NUMBER	POLICY EFF (MM/DD/YYYY)	POLICY EXP (MM/DD/YYYY)	LIMITS
A	<input checked="" type="checkbox"/> COMMERCIAL GENERAL LIABILITY <input type="checkbox"/> CLAIMS-MADE <input checked="" type="checkbox"/> OCCUR GEN'L AGGREGATE LIMIT APPLIES PER: <input type="checkbox"/> POLICY <input type="checkbox"/> PRO-JECT <input checked="" type="checkbox"/> LOC OTHER:	X	X	2507706	06/01/2024	06/01/2025	EACH OCCURRENCE \$2,000,000 DAMAGE TO RENTED PREMISES (Ea occurrence) \$500,000 MED EXP (Any one person) \$25,000 PERSONAL & ADV INJURY \$2,000,000 GENERAL AGGREGATE \$4,000,000 PRODUCTS - COMP/OP AGG \$4,000,000 \$
A	<input checked="" type="checkbox"/> AUTOMOBILE LIABILITY <input checked="" type="checkbox"/> ANY AUTO OWNED AUTOS ONLY <input checked="" type="checkbox"/> HIRED AUTOS ONLY <input checked="" type="checkbox"/> PIP \$10K <input type="checkbox"/> SCHEDULED AUTOS NON-OWNED AUTOS ONLY	X	X	2507706	06/01/2024	06/01/2025	COMBINED SINGLE LIMIT (Ea accident) \$2,000,000 BODILY INJURY (Per person) \$ BODILY INJURY (Per accident) \$ PROPERTY DAMAGE (Per accident) \$ \$
B	<input checked="" type="checkbox"/> UMBRELLA LIAB <input checked="" type="checkbox"/> EXCESS LIAB <input checked="" type="checkbox"/> DED <input checked="" type="checkbox"/> RETENTION \$0			CSX00028048Q03	06/01/2024	06/01/2025	EACH OCCURRENCE \$5,000,000 AGGREGATE \$5,000,000 Prod/Cops \$5,000,000
A	<input checked="" type="checkbox"/> WORKERS COMPENSATION AND EMPLOYERS' LIABILITY ANY PROPRIETOR/PARTNER/EXECUTIVE OFFICER/MEMBER EXCLUDED? (Mandatory in NH) If yes, describe under DESCRIPTION OF OPERATIONS below			WC048240300	06/01/2024	06/01/2025	<input checked="" type="checkbox"/> PER STATUTE <input type="checkbox"/> OTH-ER E.L. EACH ACCIDENT \$1,000,000 E.L. DISEASE - EA EMPLOYEE \$1,000,000 E.L. DISEASE - POLICY LIMIT \$1,000,000
A	Garage Liability			2507706	06/01/2024	06/01/2025	\$1,000,000
A	GarageKeepers			2507706	06/01/2024	06/01/2025	\$1,000,000 \$500 Comp/\$1,000 Coll

DESCRIPTION OF OPERATIONS / LOCATIONS / VEHICLES (ACORD 101, Additional Remarks Schedule, may be attached if more space is required)
Named Insured Schedule Includes: Coastal Industrial Equipment, LLC; Atlantic Equipment Leasing, LLC; Atlantic Truck Finance, LLC; PacLease of Jacksonville, LLC; OBSC, LLC; Ross Group Holdings, LLC. 10 Dealer Plates. Under the terms and conditions of the policies and where required by contract, the certificate holder is afforded a Blanket Additional Insured endorsement with respects to General, Auto and Umbrella Liability and Waiver of Subrogation for the General, Auto and Workers' Compensation. Umbrella is following (See Attached Descriptions)

CERTIFICATE HOLDER Nassau County Board of County Commissioners 96135 Nassau Place, Suite 2 Yulee, FL 32097	CANCELLATION SHOULD ANY OF THE ABOVE DESCRIBED POLICIES BE CANCELLED BEFORE THE EXPIRATION DATE THEREOF, NOTICE WILL BE DELIVERED IN ACCORDANCE WITH THE POLICY PROVISIONS. AUTHORIZED REPRESENTATIVE 
---	---

DESCRIPTIONS (Continued from Page 1)

form. Primary and Non-Contributory endorsements apply where required by written contract for the General and Auto Liability coverages.

30 days Notice of Cancellation to certificate holder.